

SERVICE GUIDE

Series 50 A
M1351A

Series 50 IP-2
M1353A
Fetal/Maternal Monitors

FETAL MONITORING

PHILIPS

Printed in Germany 10/04



Part Number M1353-9000K
4512 610 04691



Series 50 Fetal Monitors
Series 50 A (M1351A)
Series 50 IP-2 (M1353A)

SERVICE AND INSTALLATION GUIDE

M1353-9000K

Printed in Germany October 2004



Notice

Philips makes no warranty of any kind with regard to this material, including, but not limited to, the implied warranties of merchantability and fitness for a particular purpose. Philips Medical Systems shall not be liable for errors contained herein or for incidental or consequential damages in connection with the furnishing, performance or use of this material.

This document contains proprietary information that is protected by copyright. All rights are reserved. No part of this document may be photocopied, reproduced or translated to another language without prior written consent of Philips Medical Systems.

The information contained in this document is subject to change without notice.

Philips assumes no responsibility for the use or reliability of its software on equipment that is not furnished by Philips.

Purchase of this instrument confers no express or implied license under any Nellcor patent or copyright to use this instrument with any fetal oximetry sensor that is not manufactured or licensed by Nellcor.

TMDinamap is a trademark of General Electric.

TMPress-Mate is a trademark of the COLIN Corporation.

Federal Law (US) restricts this device to sale by or on the order of a physician.

Caution

Failure on the part of the responsible individual hospital or institution employing the use of this equipment to implement a satisfactory maintenance schedule may cause undue equipment failure and possible health hazards.

Printing History

New editions are complete revisions of the manual. Update packages, which are issued between editions, contain additional and replacement pages to be added to the manual. The dates on the title page change only when a new edition or a new update is published.

Edition 1: June 1992

Edition 2: August 1993

Edition 3: February 1995

Edition 4: March 1997

Edition 5: February 1998

Edition 6: May 2000

Edition 7: April 2002

Edition 8: October 2004

© 1990-2004 Koninklijke Philips Electronics N.V.
All Rights Reserved.

Contents

1. General Information	1
Introduction	1
Who Should Read This Guide	1
What to do Next	1
Repair Strategy	1
Conventions and Symbols Used in this Guide	2
Initial Inspection	3
Claims for Damage	3
Repacking	3
Overview	4
Major Keys and Parts at a Glance	5
Monitor Control and Display Panel	7
M1351A Single Ultrasound Model	7
M1351A Dual Ultrasound Twins Model	7
M1353A Model	8
Accessories	9
Series 50 A (M1351A)	9
Series 50 IP-2 (M1353A)	9
Documentation	10
Options	11
2. Technical Specifications	13
Monitor	13
Power Requirements	13
Environment	13
Weight and Dimensions	13
Displays	14
Inputs	14
Recorder	15
Self-Test Facilities	16
Combined Interface Module	16
Modem Interface Module	16
Remote Event Marker (15249A)	16
Transducers and Cables	17
Brown Toco Transducer (M1355A)	17
Blue Toco Transducer (M1355A)	17
Brown Ultrasound Transducer (M1356A)	17
Blue ¹ Ultrasound Transducer (M1356A)	17
DECG Transducer (M1357A)	18
MECG Transducer (M1359A)	18
DECG/MECG Patient Module (M1364A)	18
IUP Quartz Transducer (1290C option J05)	19
IUP Pressure Transducer (CPJ840J5)	20
3. Installing the Monitor	21
Fitting the Monitor to a Surface	21
Fitting the Monitor to the Angle Mount	21
Fitting the Monitor to a Wall	22
Wall Mount Dimensions	22
Fitting the Paper Take-Up Tray	23

Cart-mounted Paper Tray	23
Carts	24
Fitting the Barcode Reader Holder	24
4. Configuring the Monitor	25
Introduction	25
Configuring the Monitor Using Pushbuttons	26
Examples: How to Change the Time Format and IUP Format using Pushbuttons	28
Configuring the Monitor Using Barcodes	29
Configuring the Monitor Using a PC	29
Installing the Service Program	30
Connecting the PC to the Monitor	31
Loading the Service Program	31
Using the Service Program	31
Error Log Messages	44
5. Setting Time, Date, and Paper Speed	47
Time and Date	47
Paper Speed	48
6. Theory of Operation	49
System Overview	49
Booting and Self Tests	50
Front End Board	52
M1351A (M1353-66501 and M1353-66511)	52
M1353A (M1353-66512)	52
Frontend Board for M1353A (M1350-66517)	54
Power Supply Board (M1353-66502)	55
CPU Board (M1353-66503 and M1353-66513)	56
CPU Board M1353-66503	56
CPU Board M1353-66513	56
Display Board (M1350-66520)	58
Recorder Interface Board (M1353-66510)	59
Interface Boards	60
Combined Interface Board	60
Modem Interface Board	63
7. Tests and Error Messages	65
Service Philosophy	65
Overview of the Service Tests	65
Performance Assurance Tests	65
Self Test	65
Quick Test	66
Parameter Test	68
Operator Error Messages	69
Permanent Test	70
FSpO2	70
8. Troubleshooting Flowcharts	71
Introduction	71
Error 500: General Failure	72
Error 501, 511, 512, 516, 517: Front End Board	74
Error 502: Power Supply	76

Error 503 and 513: CPU Board	78
Error 510: Recorder Board	79
Error 531: Combined Interface Board	80
Error 532: Modem Interface Board	81
Error 70: Modem Not Responding	82
Error 77: Modem Transmission Failure	83
Error 601: Paper Feed	84
Error 610: No Loudspeaker	85
Error 611: Loudspeaker	86
Ultrasound Parameter Test	87
DECG Parameter Test	88
MECG Parameter Test	89
Toco Parameter Test	90
Maternal NIBP with the Dinamap 1846/8100 Monitor	91
Maternal NIBP with the COLIN Model BP-8800 Monitor	92
Fetal Pulse Oximetry with Nellcor N-400 or Compatible Monitor	93
Paper Sensing Test	94

9. Preventive Maintenance, Care and Cleaning 95

Introduction	95
Cleaning the Monitor	95
Regular Maintenance	96
Mechanical Inspection	96
Recorder Maintenance	96
Accessory Testing	97
Testing Toco Transducers	97
Testing Ultrasound Transducers	98
Testing Patient Modules (M1364A)	99
IUP	99
Safety Testing	100
Safety Test Procedures	100
When to Perform Safety Tests	102
Test and Inspection Matrix	103
Safety Tests	104

10. Peripherals 107

Fitting the Combined Interface Module	107
Connecting Peripheral Devices	108
RS232 Serial Interface	109
Barcode Reader	110
NIBP Monitor	111
Maternal Measurements on the FHR Trace	112
FSpO2 Monitor	113
Telemetry System	115
80235A (OBMS), M1370A (ODIS), and OB TraceVue	117

11. Replacing Parts 119

Introduction	119
Ordering Parts	119
Safety Test Requirements	119
Service Tools	120
Lists of Parts	120

Boards	120
Monitor Parts	122
Recorder Parts	126
Monitor Housing Color	127
Toco Transducer (Blue, M1355A)	128
Ultrasound Transducer (Blue, M1356A)	129
DECG Transducer (M1357A)	130
MECG Transducer (M1359A)	131
Toco Transducer (Brown)	132
Ultrasound Transducer (Brown)	134
Patient Module (M1364A)	136
Parts List	136
Troubleshooting	136
Fuses	137
Batteries	138
Top Cover	139
Front End Board	140
Power Supply Board	141
CPU Board	142
Combined Interface Module	143
Modem Interface Module	143
Chassis	144
On/Off Switch	145
Recorder Board	146
Display Board	147
Switch Board	148
Loudspeaker	149
Transformer	150
Drawer Assembly	151
Thermal Printhead	152
Recorder Sensing Assembly	154
Stepper Motor	155
A. Modem Interface Module	157
Introduction	157
Fitting the Modem Interface Module	157
Connecting Peripheral Devices	158
Barcode Reader Interface	159
RS232 Serial Interface	160
Entering, Storing, and Transmitting Data	161
Setting the Receiver Phone Number	162
Setting the Patient Phone Number	162
Setting the Patient ID	162
Clearing Memory	163
Starting Storage	163
Displaying Memory	164
Stopping the Storage or Transmission of Data	164
Transmitting Data	164
PCMCIA Card Modem	165
Modem Compatibility	166
Modem Initialization	166
Using the Modem Setup Barcodes	166
List of Parts	167
Troubleshooting and Error Messages	167

Telephone Connection	168
Modem Setup Barcodes	170
Service Barcodes	170
B. Safety and Environment	173
Safety Information	173
Protective Earth	173
Patient Safety	173
Series 50 A	174
Series 50 IP-2	174
Environment	174
Spillage	175
Electromagnetic Compatibility (EMC) Specifications	175
Emissions and Immunity	175
Electromagnetic Emissions	176
Electromagnetic Immunity	176
Finding Recommended Separation Distances	177
Recommended Separation Distances from Portable and Mobile RF Communication Equipment	179
C. Upgrade Key	181
Introduction	181
Upgrade Procedure	181

Introduction

This guide tells you how to install, service, and repair an Series 50 A (M1351A) and an Series 50 IP/IP-2 (M1353A) fetal monitor. Throughout this book, the M1353A is referred to as the IP-2. This also covers the IP, unless stated otherwise. It describes the system hardware and software, and tells you how to test the system and diagnose operating and service problems.

It gives instructions for both the Series 50 A and the Series 50 IP/IP-2 monitors. The features available on the monitor you are installing or servicing depend on which options have been purchased. If your monitor does not have a described parameter, you can skip that part of the instruction and move on to the next point.

Who Should Read This Guide

The manual is for anyone who services and repairs Series 50 A (M1351A) and Series 50 IP/IP-2 (M1353A) fetal monitors. You must understand English and be familiar with current conventional technical terms.

What to do Next

Familiarize yourself with the contents of this guide before attempting to install or service the monitor.

Repair Strategy

Reading operating error messages and the error log helps you to determine whether a fault is a hardware or software problem. Faults may be repaired by replacing a board when possible, or exchanging the monitor. Repair or replacement of components on the boards should not be attempted.

After any repairs you must carry out the following tests:

- Performance test, by running the Self Test (see page 65).
- Quick Test (see page 66).
- Parameter Test (see page 68).

You must also perform the appropriate safety tests (see the section “Safety Testing” on page 100).

A series of preventive maintenance tasks and performance assurance tests must be carried out regularly to ensure the proper functioning of the monitor: these are described in “Regular Maintenance” on page 96.

Conventions and Symbols Used in this Guide

This guide uses the following conventions for notes, cautions, and warnings:

Warning

A warning alerts you to a potential serious outcome, adverse event or safety hazard. Failure to observe a warning may result in death or serious injury to the user or patient.

Caution

A caution alerts you to situations where special care is necessary for the safe and effective use of the product. Failure to observe a caution may result in minor or moderate personal injury or damage to the product or other property, and possibly in a remote risk of more serious injury.

Note— A note calls your attention to an important point in the text.



On your monitor, this sign indicates that there is detailed information in this book and the *Instructions For Use* which you must read before proceeding with your task

Equipotential Terminal



This symbol is used to identify terminals which are connected together, bringing various parts of an equipment or system to the same potential, not necessarily being earth potential (the value of potentials of earth may be indicated adjacent to the symbol).

Protective Earth Terminal



This symbol identifies the terminal for connection to an external protective earth.

Initial Inspection

The monitor and any supporting options ordered are supplied packed in protective shipping cartons. Before unpacking, visually check the packaging and ensure that there are no signs of mishandling or damage.

Claims for Damage

If the shipping cartons show signs of having been mishandled, contact the carrier and arrange for his agent to make an inspection.

If any of the equipment supplied is damaged, you should contact both the carrier and your local Philips Medical Service Organization. Arrangements will then be made for repair or replacement, as appropriate.

Repacking

You are advised to retain the original packing carton and material. You will find it useful if it becomes necessary to return a piece of equipment to Philips for service. If you need to repack the equipment but cannot locate the original packing materials, Philips can advise you on alternatives.

Overview

This guide describes three different Series 50 Fetal Monitor models:

- M1351A Single Ultrasound model (with US and Toco channels).
- M1351A Dual Ultrasound Twins model (with US1, Toco and US2 channels).
- M1353A model (with US1, Toco and US2/ECG channels).

The M1351A single and double ultrasound model is for external monitoring of FHR and uterine activity in the antenatal period from early gestation (approximately 20 to 25 weeks) to term. The M1353A is for monitoring FHR, including twins, maternal heart rate and uterine activity. FHR and uterine activity can be monitored externally in the antenatal period from early gestation to term, and internally throughout labor and delivery. The basic capabilities of the three models are summarized in the table below.

Table 1-1 Fetal Monitor Parameters

Parameter	M1351A Single	M1351A Twin	M1353A
Monitor FHR using ultrasound	Yes	Yes	Yes
Monitor twin FHRs using ultrasound	No	Yes	Yes
Monitor twins using DECG and ultrasound	No	No	Yes
Monitor FHR using DECG	No	No	Yes
Monitor uterine activity using Toco ext	Yes	Yes	Yes
Monitor IUP	No	No	Yes
Monitor maternal heart rate	No	No	Yes
Detect fetal movements ¹	Yes	Yes	Yes
Mark events	Yes	Yes	Yes
Record nursing notes ¹	Yes	Yes	Yes
Transmission of fetal trace information ¹	Yes	Yes	Yes
Fetal trace memory ¹	Yes	Yes	Yes
Interfacing to fetal pulse oximetry	Yes	Yes	Yes

1. May be ordered as an option for all models

Major Keys and Parts at a Glance

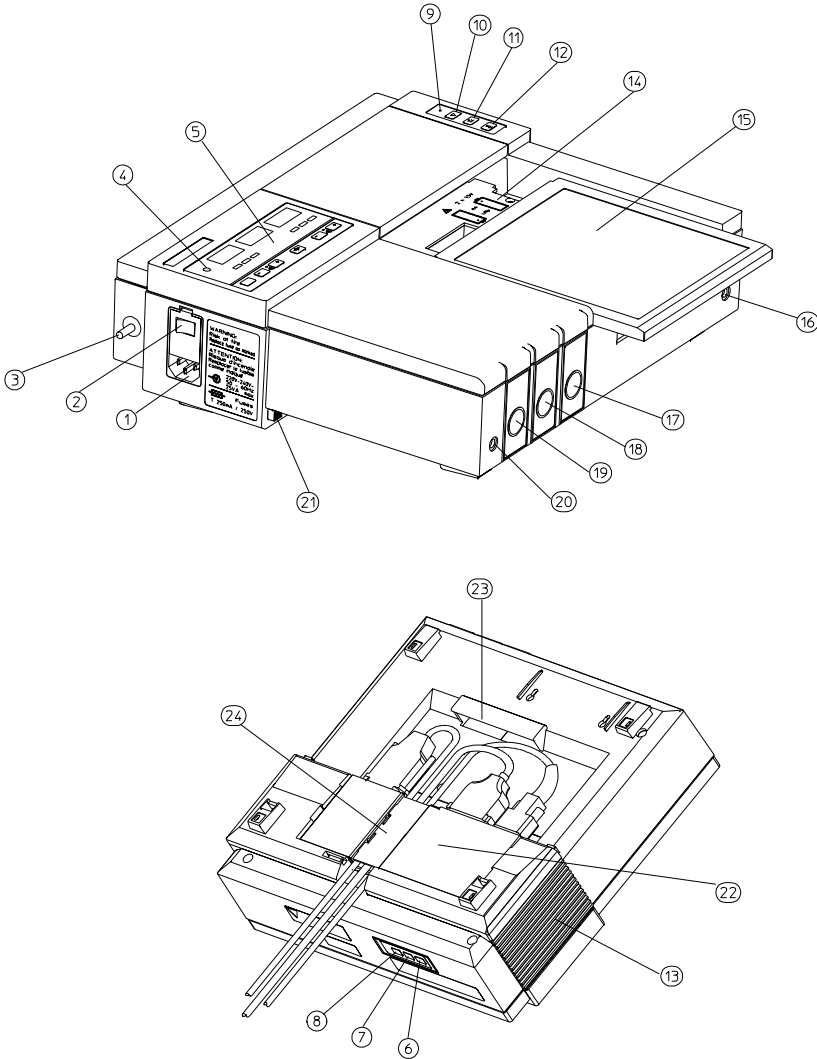

Figure 1-1 General Layout of the Series 50 A and Series 50 IP-2 Fetal Monitors

Major Keys and Parts at a Glance

1. Mains socket
2. Monitor on/off switch
3. Equipotential grounding point
4. Monitor on/off light
5. Display panel
6. Time and date key
7. Paper speed key
8. Test key
9. Recorder on/off light
10. Recorder on/off key
11. Event marker key (Alert acknowledge key)
12. Paper advance key
13. Loudspeaker
14. Battery compartment
15. Paper table
16. Service socket
17. *Series 50 A:* US2 Socket (not present on Single Ultrasound model)
Series 50 IP-2: US2/ECG Socket
18. Toco socket
19. *Series 50 A:* Single Ultrasound Model: US Socket
Double Ultrasound Model: US1 socket
Series 50 IP-2: US1 socket
20. Socket for remote event marker
21. Lock-release button
22. Combined interface module
23. Integrated carrying handle
24. Cable clamp

Monitor Control and Display Panel

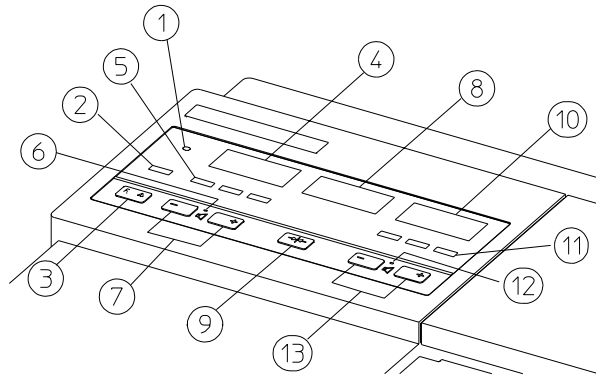

Figure 1-2 Layout of the Monitor Control and Display Panel

M1351A Single Ultrasound Model

1. **Monitor On/Off Light.**
2. **Telemetry Indicator.** On when the Fetal Telemetry Receiver is connected and switched on.
3. **Function Key.** Used to switch FMP and Fetal Alerting on and off.
4. **US Display.** Shows the FHR detected by the US transducer.
5. **US Signal Quality Indicator.** Indicates the quality of the signal detected by the US transducer:
 - Green (optimum).
 - Yellow (fair to potentially poor).
 - Red (unacceptable).
6. **US Speaker Light.** On when you are hearing the US heartbeat.
7. **US Volume Keys.** Sets the volume and selects the US heartbeat.
8. **Toco Display.** Shows uterine activity.
9. **Toco Baseline Key.** Zeroes the Toco display and trace to 20 units.

M1351A Dual Ultrasound Twins Model

1. **Monitor On/Off Light.**
2. **Telemetry Indicator.** On when the Fetal Telemetry Receiver is connected and switched on.
3. **Function Key.** Used to switch Twins Offset, FMP, and Fetal Alerting on and off.
4. **US1 Display.** Shows the FHR detected by the US1 transducer.

5. **US1 Signal Quality Indicator.** Indicates the quality of the signal detected by the US1 transducer.
6. **US1 Speaker Light.** On when you are hearing the US1 heartbeat.
7. **US1 Volume Keys.** Sets the volume and selects the US1 heartbeat.
8. **Toco Display.** Shows uterine activity.
9. **Toco Baseline Key.** Zeroes the Toco display and trace to 20 units.
10. **US2 Display.** Shows the FHR detected by the US2 transducer.
11. **US2 Signal Quality Indicator.** Indicates the quality of the signal detected by the US2 transducer.
12. **US2 Speaker Light.** On when you are hearing the US2 heartbeat.
13. **US2 Volume Keys.** Sets the volume and selects the US2 heartbeat.

M1353A Model

1. **Monitor On/Off Light.**
2. **Telemetry Indicator.** On when the Fetal Telemetry Receiver is connected and switched on.
3. **Function Key.** Used to switch Twins Offset, Logic, FMP, and Fetal Alerting on and off.
4. **US Display.** Shows the FHR detected by the US transducer.
5. **US1 Signal Quality Indicator.** Indicates the quality of the signal detected by the US1 transducer:
6. **US1 Speaker Light.** On when you are hearing the US1 heartbeat.
7. **US1 Volume Keys.** Sets the volume and selects the US1 heartbeat.
8. **Toco Display.** Shows uterine activity.
9. **Toco Baseline Key.** Zeroes the Toco display and trace to 20 units (when monitoring externally) or 0 units (when monitoring internally).
10. **US2/ECG Display.** Shows the FHR detected by the ECG transducer.
11. **US2/ECG Signal Quality Indicator.** Indicates the quality of the signal detected by the ECG transducer.
12. **US2/ECG Speaker Light.** On when you are hearing the ECG heartbeat.
13. **US2/ECG Volume Keys.** Sets the volume and selects the ECG heartbeat.

Accessories

Series 50 A (M1351A)

The following accessories are supplied as standard with the Monitor:

- One external Toco transducer (M1355-60011).
- One ultrasound transducer (M1356-60011) (or two with the Dual Ultrasound Model).
- Two reusable transducer belts (M1562A) (or three with Dual Ultrasound Model).
- Three transducer knob adapters (M1356-43201).
- One power cord.
- One pack of paper:
 - M1910A (USA/Canada)
 - M1911A (Europe)
 - M1913A (Japan)
- One bottle of gel: 40483A (Acquasonic gel)
- One User's Guide.
- One Installation and Service Guide
- One remote event marker (15249A).

Series 50 IP-2 (M1353A)

The following accessories are supplied as standard with the Monitor:

- One external Toco transducer (M1355-60011).
- One ultrasound transducer (M1356-60011).
- One patient module M1364A with cables:
 - One DECG legplate adapter cable (M1362B)
 - One MEKG adapter cable (M1363A)
- Five spiral electrodes:
 - 15133D Single spiral (USA).
 - 15133E Double spiral (Europe).
- Three reusable transducer belts.
- Three transducer knob adapters (M1356-43201).
- One power cord.
- Equipotential grounding cable:

Accessories

- 8120-2961 (USA).
- 8120-4808 (Europe).
- One pack of paper:
 - M1910A (USA/Canada)
 - M1911A (Europe)
 - M1913A (Japan)
- One bottle of gel: 40483A (Acquasonic gel)
- One Instructions for Use.
- One Installation and Service Guide.

Documentation The following documentation is available for the Series 50 A and Series 50 IP-2 fetal monitors. Unless otherwise specified localized versions are available.

- Technical Data Sheets: Contain features and benefits, technical specifications, accessories, ordering, upgrading and re-ordering information.
- Service Documentation: All service documentation is in English.
- Instructions for Use: Detailed operating information, care and cleaning, and safety requirements.
- Video Tapes: 30-minute VHS video tapes demonstrating the Monitor.
- Barcode Booklets: Labels and cards, and instructions on how to customize sheets of nursing notes.
- Digital Interface Protocol Specifications: Written as a programmer's guide, describing the data exchange between the Series 50 Fetal Monitors and an Information Management System such as OB **TraceVue**. English only.

Options

The following accessories can also be supplied when the appropriate option is ordered.

Accessories	Option	Model
Barcode Reader , including a reader and barcode booklet. This requires Option J10 or J15.	H15	Series 50 A and Series 50 IP
Combined Interface Module for telemetry and obstetrical surveillance systems (e.g. Philips OB TraceVue) and barcode reader	J10 ¹	Series 50 A and Series 50 IP
Combined Interface Module for telemetry and obstetrical surveillance systems (e.g. Philips OB TraceVue), includes an interface cable M1350-61609. <ul style="list-style-type: none"> for Dinamap 1846 or COLIN Press-Mate/Nippon Colin Listmini Model BP-8800 NIBP Monitor 	J13 ¹	Series 50 A and Series 50 IP
Combined Interface Module for telemetry and obstetrical surveillance systems (e.g. Philips OB TraceVue), includes an interface cable M1353-61614 <ul style="list-style-type: none"> for Nellcor OxiFirst™ Fetal Oxygen Saturation Monitor (N-400) 	J14 ¹	Series 50 A and Series 50 IP
Modem Interface Module allows the transmission of fetal trace data from a Series 50 A to a receiver (e.g., an OB TraceVue system)	J15 ¹	Series 50 A
Fetal Movement Profile	C02	Series 50 A and Series 50 IP
IUP Pressure Transducer (CPJ840J5)	C07	Series 50 IP
Disposable IUP Catheter . This includes 1 x box M1333A (containing 10 catheters) disposable intrauterine sensor-tip pressure catheters and M1334A reusable connector cable	C08 ²	Series 50 IP

1. Options J10, J13, J14 and J15 cannot be fitted at the same time

2. Not available in all countries.

Accessories	Option	Model
Service and Installation Guide	0B3	Series 50 A and Series 50 IP
Installation and Operating Guide Video <ul style="list-style-type: none"> • VHS/NTSC • VHS/PAL 	0B5	Series 50 A and Series 50 IP
Wall mounting kit	1AB	Series 50 A and Series 50 IP
Paper take-up tray ¹	1AC	Series 50 A and Series 50 IP
Angled mounting kit	1AD	Series 50 A and Series 50 IP
Mobile cart	2AE	Series 50 A and Series 50 IP

1. Not compatible with the wall mounting kit.

Technical Specifications

Monitor

Power Requirements

The monitor is set for the correct voltage at the factory. Before you connect power, however, ensure that the voltage label shows the correct setting for your country.

Operating Voltage: 100V - 120V~ or 220V - 240V ($\pm 10\%$).

Line Frequency: 50 to 60Hz $\pm 5\%$.

Power Consumption: 25VA max.

Battery Type: 2 x 1.5V (AA size). Lifetime > 1 year.

Environment

The monitor should be used in an environment which is reasonably free from vibration, dust, corrosive or explosive gases, extremes of temperature, humidity, etc. It operates within specifications at ambient temperatures between 0 and 55°C. Ambient temperatures which exceed these limits can affect the accuracy of the monitor and cause damage to the components and circuits. Allow at least 5cm (2in) clearance around the monitor for proper air circulation.

Operating Temp: 0 to +55°C (32°F to 131°F).

Storage Temp: -40 to +75°C (-40°F to 167°F), excludes transducers: -40 to +60°C (-40°F to +140°F)

Relative Humidity: 5 to 95%.

Weight and Dimensions

Height: 115mm (4.5in).

Width: 340mm (13.4in).

Depth: 308mm (12.1in).

Weight: 5.74kg (12.6lb) (without transducers).

Displays

Numerical Display M1351A Single
Ultrasound Model: One heart rate display (orange) and one uterine activity display (green).

M1351A Dual

Ultrasound Twins Model: Two heart rate displays and one uterine activity display.

M1353A Model: Two heart rate displays and one uterine activity display.

Type: 7-segment LEDs (10mm).

FHR Range: 50 to 240 bpm.

Uterine Activity Range: -99 to +127 relative units.

Instrument Display Telemetry Mode is displayed if Option J10 is fitted and an M2720A Avalon CTS Cordless Fetal Transducer System or M1310A or 80240A Fetal Telemetry System is connected and switched on.

M1351A Single

Ultrasound Model: One signal quality indicator.

M1351A Dual

Ultrasound Twins Model: Two signal quality indicators.

M1353A Model: Two signal quality indicators.

Inputs

M1351A Single

Ultrasound Model US socket accepts the M1356A ultrasound transducer. Toco socket accepts the M1355A Toco transducer. Socket for the Remote Event Marker (15249A), and another for servicing. The monitor automatically selects the correct operating mode.

M1351A Dual

Ultrasound Twins Model US1 and US2 sockets accept M1356A ultrasound transducers. Toco socket accepts the M1355A Toco transducer. Socket for the Remote Event Marker (15249A), and another for servicing. The monitor automatically selects the correct operating mode.

M1353A Model

US1 socket accepts the M1356A ultrasound transducer. Toco socket accepts the M1355A external Toco or the M1350A/8040A compatible internal Toco transducer. US2/ECG socket accepts either the M1356A ultrasound transducer, or the M1364A DECG/MECG patient module or the M1357A DECG or the M1359A MECG transducer. There is a socket for the remote event marker (15249A), and another for servicing. The monitor automatically selects the correct operating mode.

Ultrasound Mode	System:	Pulsed Doppler oscillation.
	Frequency:	998.4 kHz.
	Repetition Rate:	3.2 kHz.
	Ultrasound Intensity:	1.5mW/cm ² average for each of the seven active surfaces.

DECG and MEGC Mode See Specifications for Transducers and Cables on page 17.

External Labor	Signal Range:	0 to 127 units.
	Offset Compensation:	±200 units.

Internal Labor	Signal Range:	-99 to +127 mmHg.
	Patient Leakage Current:	≤10 μA _{rms} .
	Sensitivity:	40 μV/V/mmHg (M1348A). 5 μV/V/mmHg (M1334A and CPJ840J5).

Recorder	Mechanism:	3-channel, high-resolution (8 dots/mm) thermal array recorder with paper-end detection.
	Paper Speeds:	1, 2 or 3 cm/min.
	Recording Time Per Pack of Paper:	1 cm/min (25 h). 2 cm/min (12 h 30 min). 3 cm/min (8 h 20 min).
	Paper Advance Speed:	24 cm/min (with automatic stop at the paper-end mark).
	Annotation:	Time of day, date, and paper speed are printed automatically every ten minutes. Monitoring mode is printed with every alteration of parameter.
	Paper:	Fanfold paper with numbered pages.
	FHR Scale:	USA: 30 to 240 bpm @ 30 bpm/cm. Other countries: 50 to 210 bpm @ 20 bpm/cm.
	Labor Scale:	0 to 100 units @ 25 units/cm.

Self-Test Facilities

Self-test facilities include:

- System test:** With no transducers connected (includes a display and recorder test).
- Parameter test:** With the appropriate transducer connected, the monitoring mode (ultrasound or uterine activity) is tested.

Combined Interface Module

- Telemetry:** M1310A Fetal Telemetry System.
- System:** M1383A/B/C OB **TraceVue**.
- Either
- Barcode Reader:** SmartWand.
- or
- Maternal NIBP Monitor:** Dinamap™1846/8100.
COLIN Press-Mate™/Nippon Colin Listmini Model BP-8800.
or
Nellcor OxiFirst™ Fetal Oxygen Saturation Monitor (N-400) or compatible.

Modem Interface Module

- Modem:** Interface socket for an Philips-approved PCMCIA card modem.
- Fetal Trace Memory:** Local fetal trace storage.
- Barcode Reader:** Smart Wand.
- RS232 Serial Interface:** For internal use only.

Remote Event Marker (15249A)

- Length:** 2.8m/9ft 2in.
- Weight:** 75g/2.65oz.

Transducers and Cables

Transducers can be stored at temperatures between -40 and +60°C.

Brown Toco Transducer (M1355A)

System:	Passive Straingauge.
Dynamic Range:	0 to 12N (overload protected).
Weight:	180g/6.3oz.
Cable Length:	2.5m/8ft 2in.

Blue¹ Toco Transducer (M1355A)

System:	Passive Straingauge.
Dynamic Range:	0 to 12N (overload protected).
Weight:	180g/6.3oz.
Cable Length:	2.5m/8ft 2in or 0.7m/2ft 3in.

Brown Ultrasound Transducer (M1356A)

System:	Pulsed Doppler.
Oscillator Frequency:	998.4kHz.
Weight:	185g/6.5oz.
Cable Length:	+ 2.5m/8ft 2in.
Size:	75mm/2.95in diameter.

Blue¹ Ultrasound Transducer (M1356A)

System:	Pulsed Doppler.
Oscillator Frequency:	998.4kHz.
Weight:	185g/6.5oz.
Cable Length:	2.5m/8ft 2in or 0.7m/2ft 3in.
Size:	75mm/2.95in diameter.

1. Indicates transducer is waterproof.

**DECG
Transducer
(M1357A)**

Input Impedance:	>10M Ω (differential, dc to 50/60Hz).
CMRR:	>110dB (with patient cable, 51.5k Ω /0.047 μ F imbalance at line frequency).
Noise:	<4 μ V _p (referred to input with 25k Ω).
Contact Potential Tolerance:	\pm 400mV.
Input Voltage Range:	20 μ V _p to 3mV _p .
Patient Leakage Current:	<10 μ A _{rms} @ 120V/60Hz.
Patient Auxiliary Current:	<0.1 μ A (dc).
Dielectric Strength:	1500V _{rms} (spark-gap protected).
Weight:	185g/6.5oz.
Cable Length:	2.5m/8ft 2in or 0.7m/2ft 3in.

**MECG
Transducer
(M1359A)**

Input Impedance:	>10M Ω (differential, dc to 50/60Hz).
CMRR:	>90dB (with patient cable, 51.5k Ω /0.047 μ F imbalance at line frequency).
Noise:	<4 μ V _p (referred to input with 25k Ω).
Contact Potential Tolerance:	\pm 400mV.
Input Voltage Range:	80 μ V _p to 4mV _p .
Patient Leakage Current:	<10 μ A _{rms} @ 120V/60Hz.
Patient Auxiliary Current:	<0.1 μ A (dc).
Dielectric Strength:	1500V _{rms} (spark-gap protected).
Weight:	175g/6.2oz.
Cable Length:	2.5m/8ft 2in.

**DECG/MECG
Patient Module
(M1364A)**

The patient module has a 7-pin ECG connector into which you can plug either DECG cable (M1362A or B) or MECG cable (M1363A).

Overall length: 2706mm (+30, -100mm)

Length of free cable: 2618mm (+30, -100mm)

Weight: 120 grams

Size: 88x42x30mm

Socket: DECG or MECG connection

DECG Cable (M1362A)	Cable weight: 22 grams Cable Length: 666mm +/- 30mm
DECG Adaptor Cable (M1362B)	Cable weight: 35 grams (approx.) Cable Length: 77cm (approx.)
MECG Cable (M1363A)	Cable weight: 16 grams Cable Length: 606mm +/-30mm
M1364A With DECG Cable M1362A	Patient Leakage Current: 120V at 60Hz, 10 μ A rms Patient Auxiliary Current: < 0.1 μ A (dc) Dielectric strength: 1500Vrms spark gap protected Input Impedance: > 10M Ω CMRR: with patient cable, 51.5k Ω /0.047 μ F imbalance at line frequency > 110dB Noise: (referred to input with 25k Ω) < 4 μ Vp Contact Potential Difference: \pm 500mV Input Voltage Range: 20 μ Vp to 3mVp
M1364A With MECG Cable M1363A	Patient Leakage Current: 120V at 60Hz, 10 μ A rms Patient Auxiliary Current: < 0.1 μ A (dc) Dielectric strength: 1500Vrms spark gap protected Input Impedance: > 10M Ω CMRR: with patient cable, 51.5k Ω /0.047 μ F imbalance at line frequency > 80dB Noise: (referred to input with 25k Ω) < 4 μ Vp Contact Potential Difference: \pm 500mV Input Voltage Range: 80 μ Vp to 4mVp
IUP Quartz Transducer (1290C option J05)	Dynamic Range: -50 to 300mmHg. Sensitivity: 5 μ V/V/mmHg. Non-linearity: Whichever is greater: \pm 1% of the reading or \pm 1mmHg. Volume Displacement: 0.2mm ³ /100mmHg. Weight: 180g/6.3oz. Cable Length: 3m/9ft 10in. Length: 66mm/2.6in.

Width: 37mm/1.5in.
Height: 21.7mm/0.9in.
Operating Temp: 15 to 40°C.

**IUP Pressure
Transducer
(CPJ840J5)**

Pressure range: -20 to + 300 mm Hg
Max. overpressure: 10,000 mm Hg
Sensitivity: 5 μ V/V/mmHg
Resonance frequency: 300 Hz typical (transducer and dome)
Max. electrical excitation: 15 V DC or AC
Bridge resistance: 1000 Ohms (input and output)
Non-linearity and hysteresis: max. 0.5% of full scale
Zero balance: max. 0.15 mm Hg/°C
Operating temperature range: +10 to +50°C
Storage temperature range: -20 to +70°C
Isolation resistance: min. 1000 MOhms
Leakage current: max.1.5mA at 250V, 50 Hz
Weight: 24 grams (without cable)
Connector: Equipment specified

Installing the Monitor

Fitting the Monitor to a Surface

The monitor can be mounted on (but not fixed to) an existing surface.

Fitting the Monitor to the Angle Mount

To fit the monitor to the angle mount:

1. Holding the monitor at a slight angle, put the front feet into the holes (A).
2. Lower the monitor till the back feet “click” into the holes (B). Make sure that all four feet are located firmly in place.

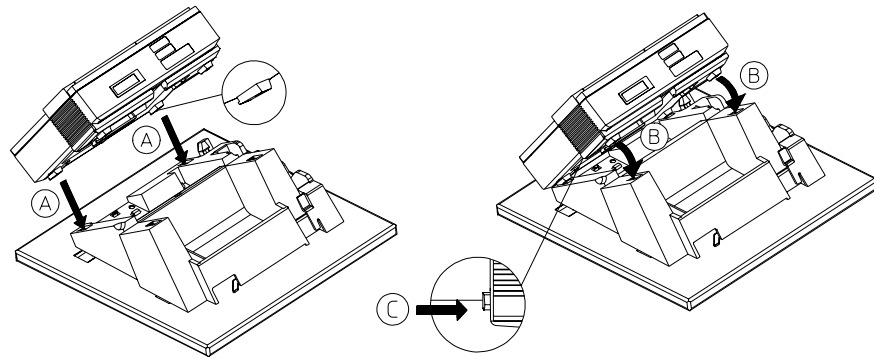

Figure 3-1 Fitting the Monitor to the Angle Mount

To remove the monitor from the angle mount hold the monitor in both hands, press both lock-release buttons (C) simultaneously and remove the monitor from the angle mount. The lock mechanism may break if it is not fully released!

Fitting the Monitor to a Wall

Before you can fit the monitor to the wall, you must first secure the mounting plate to the wall. For details of how to fit this plate to the wall, refer to the instructions supplied with it.

To fit the monitor to the plate:

1. Holding the monitor at a slight angle, put the front feet into the holes (A).
2. Push the monitor upright till the back feet “click” into the holes (B).

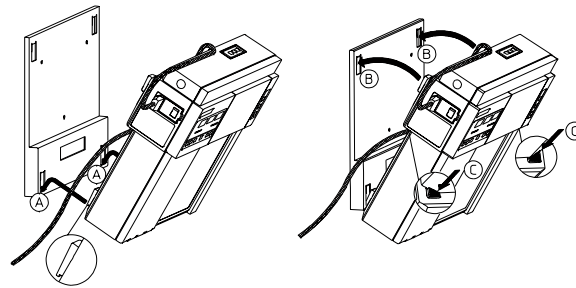

Figure 3-2 Fitting the Monitor to the Wall Mount

To remove the monitor from the plate:

1. Hold the monitor in both hands
2. Press both lock-release buttons (C) simultaneously and lift the monitor away from the plate.

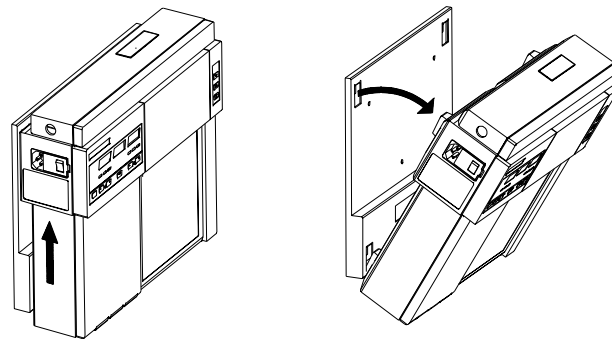

Figure 3-3 Removing the Monitor from the Wall Mount

Wall Mount Dimensions

The wall mount is a metal plate that measures:

Width:	314mm (12.36 inches).
Height:	268 mm (10.55 inches).
Depth:	26 mm (1.03 inches).

Fitting the Paper Take-Up Tray

To fit the paper take-up tray to the monitor:

1. Slide the tray between the guides (A) until the pins locate in the holes (B).
2. Pull the tray forward to lock it in place.

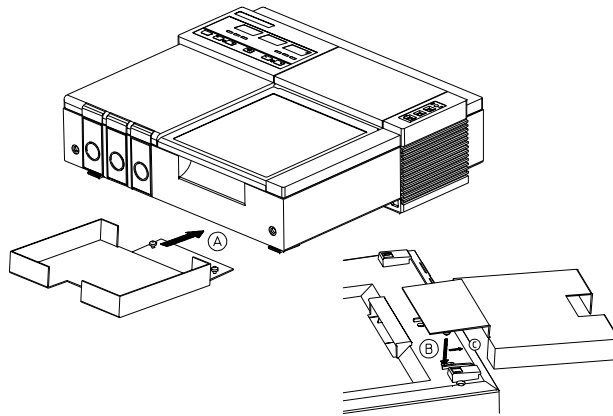

Figure 3-4 Fitting the Paper Take-Up Tray to the Monitor

To fit the paper take-up tray (Option 1AB) to the mounting plate:

1. Holding the tray at a slight angle, put the top edge in the slot on the plate.
2. Swing the tray down into place.

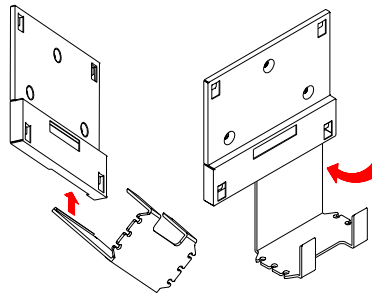

Figure 3-5 Fitting the Paper Take-Up Tray to the Wall Mount

Cart-mounted Paper Tray

Attach the paper tray before installing the monitor on the angle mount. Slide the paper tray into position so that the small hole in the attaching edge at the rear of the paper tray hooks over the mounting projection in the angle mount itself. This secures the paper tray to the angle mount.

Carts

You can mount the Series 50 A and the Series 50 IP-2 fetal monitors on the CL, CM or CX carts. Cleaning instructions for the carts and safety details are provided in the Carts Equipment Note delivered with your cart.

Table 3-1 Carts: Specifications

Specifications	Carts		
	CL (M1323A)	CM (M1324A)	CX (M1325A)
Width (mm)	514	614	614
Depth (mm)	625	625	625
Height (mm)	805	989	1117
Weight (kg)	24.2	50.6	63.4

Table 3-2 Carts Replacement Parts

Replacement Parts	Part numbers	Cart CL (M1323A)	Cart CM (M1324A)	Cart CX (M1325A)
Wheels	M1324-42100	X	✓	✓
	M1323-42075	✓	X	X
Drawers	M1324-68500	X	✓	✓
	M1323-68450	✓	X	X
CAM Mounting Arm Kit	5061-8340	✓	✓	✓
Mounting Kit IUP Pole	80310-68701	✓	✓	✓
Infusion Pole Mount	5061-8364	✓	✓	✓
Mounting Rail Kit	5061-8365	✓	✓	✓

Fitting the Barcode Reader Holder

To fit the Barcode Reader holder (HBCS-2998) to the monitor or cart:

1. Using ethanol, clean the surface of the monitor or cart thoroughly.
2. Peel off the backing from the adhesive strip and press the holder firmly into place.

Before using the holder, allow 24 hours for the adhesive to set.

Configuring the Monitor

Introduction

This chapter describes how to configure the monitor including time and date format, paper speed, and IUP scale. You can configure the monitor using any of the following methods:

- Pushbuttons
- Barcode Reader
- PC

The tasks you can carry out are summarized in Table 4-1. To find out how to set the current time, date, and paper speed, see Chapter 5, “Setting Time, Date, and Paper Speed.”

Table 4-1 Configuration Tasks

Task	Buttons	Barcode Reader	PC
Configure the time format	✓	✓	✓
Configure the date format	✓	✓	✓
Configure the IUP format	✓	✓	✓
Configure the paper format	✓	✓	✓
Configure the recorder print offset	✓	✗	✓
Configure the recorder heat adjust	✓	✗	✓
Configure the language option	✓	✗	✗
Marker for alert acknowledgement at Marker button	✓	✗	✗
Configure note transmission on/off	✓	✗	✗
Configure interface setting	✓	✗	✗
Read the options installed	✗	✗	✓
Run the cyclic test	✗ ^{1.}	✗	✓
Run the permanent test	✓ ^{2.}	✗	✗
Read the error log	✗	✗	✓
Print the error log	✓ ^{2.}	✗	✗
Clear the error log	✓ ^{2.}	✗	✓
Write the serial number and set the options	✓	✗	✓
Enable fetal pulse oximetry interface	✓	✗	✗
Enable maternal blood pressure interface	✓	✗	✗
Enable NST timer, paper out alert	✓	✗	✗

1. However you can run the Permanent Test, which is similar. See page 70 for details.

2. See “Printing the Error Log” on page 38 for details

Configuring the Monitor Using Pushbuttons

You can use the pushbuttons to set such settings as, time format, date format, IUP scale, paper format, recorder scale offset, recorder heat, and language options.

To change a setting:

1. Disconnect all transducers from the monitor and disconnect or switch off Telemetry.

2. While pressing , press **Test**.

The display shows **C01** in the US1/US display and **0** or **1** in the Toco display.



3. Scroll through the menu by pressing the  or  key until you arrive at the menu item you want to change. The menu items and their settings are shown in Table 4-2.
4. Press the  key to change the setting (**0** or **1**).
5. Press **Test** to store the new settings, or wait about 15 seconds without making any keystrokes.

Table 4-2 Configuration Options

Menu	Setting	Options	Default
C01	Time Format	0=AM/PM 1=24-hour	0
C02	Date Format	0=Month/Day/Year 1=Day.Month.Year	0
C03	IUP Format	0=mmHg 1=kPa	0
C04	Paper Format	0=US (30-240) 1=Europe (50-210)	0
C05	Recorder Print Offset ¹ .	0 to 11 0=right 1=left	0
C06	Recorder Heat Adjust	0 to 11 0=minimum 11=maximum	11
C07	Language Option	1=International 2=French 10=Japanese 13=Chinese simplified	1
C08	System Alert acknowledge at Marker button	0=off 1=on	0
C09	Note Output to System	0=off 1=on (Roman 8).	1
C10	Combined Interface Module Settings ²	0=Barcode Reader 1=Dinamap™ 1846/8100 NIBP Monitor 2=COLIN Model BP-8800 NIBP Monitor 3=Nellcor OxiFirst™ FSpO ₂ Monitor (N-400)	0
C11	External Toco gain	0=100% External Toco gain 1=50%	0
C12	NST Timer, Paper-Out-Alert ³ .	See Table 4-3	4
C15	Remote Patient Data after phone transmission	0=Clear remote patient data 1=Keep remote patient data	0
A01	Print Error Log ⁴ .		
A02	Clear Error Log ⁴ .		
A03	Start Permanent Test ⁴ .		

1. To find the correct setting, connect a *resting* Toco transducer (one that is not under any load) to the monitor and then change the setting until the trace is recording 20 units on the paper. Because of the 15-second time-out feature, and the delay between changing the setting and seeing the change on the paper, you may have to repeat this procedure to set the offset.

2. The interface to an NIBP monitor is only available on the Combined Interface Module with the label M1353-66531,E.

3. The NST auto recorder off option switches the recorder off automatically (advancing the paper to the next perforation) once the NST time set has passed.

4. See -38 for more information on these menu items.

Table 4-3 NST Timer Paper-Out-Alert

Options	NST Timer	NST automatic recorder off	Paper-Out-Alert
0	X	X	X
1	✓	X	X
2	✓	X	X
3	X	X	✓
4	✓	X	✓
5	✓	✓	✓

Note— After you put paper into the recorder, let it run for a few pages (use the advance key) to allow the paper to align itself correctly to the right side.

Examples: How to Change the Time Format and IUP Format using Pushbuttons

Example 1:

To change the time format from AM/PM format to 24-hour format, do the following:

1. Disconnect all transducers from the monitor and disconnect or switch off Telemetry.
2. While pressing **F.▲**, press **Test**.
3. Press the **←→** key to change the setting to **1**.
4. Press **Test** to store the new settings.

Example 2:

To change the IUP format from mmHg to kPa, do the following:

Disconnect all transducers from the monitor and disconnect or switch off Telemetry.

While pressing **F.▲**, press **Test**.

Press **+** repeatedly until **C03** is displayed.

Press the **←→** key to change the setting to **1**.

Press **Test** to store the new settings.

Configuring the Monitor Using Barcodes

The time format, date format, IUP scale and paper format can be set using barcodes. To select a setting using a barcode, read the required barcode from the separate *Feature Setting Sheet* provided with the Barcode Reader Kit.
To configure the Modem Interface Module using a Barcode Reader, refer to “Using the Modem Setup Barcodes” on page 164.

Configuring the Monitor Using a PC

The service program (M1360-68875) allows you to carry out various extended configuration and service functions on the monitor. Contact your Philips Sales Office for details.

The Software Program is supplied in a kit which contains:

- 3.5 inch disk containing the software.
- Cable adapter for connecting to a PC.

The program can be run on an industry-standard PC. To use the program with a Vectra, you must replace the adapter on the end of the cable with the one provided, and copy the software onto a disk.

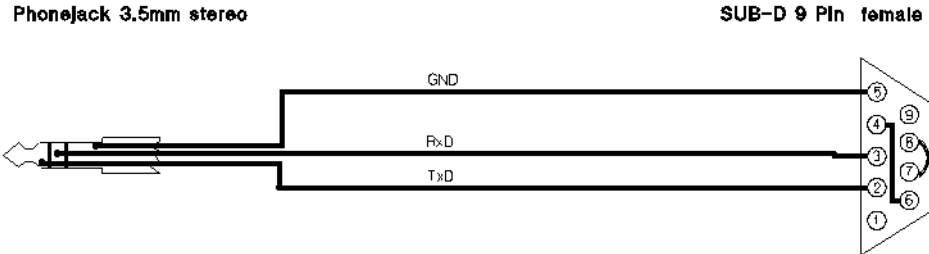

Figure 4-1 Cable for an Industry Standard compatible PC

Installing the Service Program

Before you install the program, ensure that the serial port COM1 is set up as follows:

Transmission Rate	9600 BPS
Parity	None
Word length (bits)	8
Stop-bits	1

This is done by giving the mode command (**mode com1:96,N,8,1**) at the DOS prompt. Refer to your MS-DOS Manual for details.

To install the program:

1. Switch on the PC.
2. Create a directory for the program files. For example, to create a directory called **service**, at the DOS prompt type in:

```
md service
```

and press **Enter**.

3. Insert the program disk into drive A.
4. At the DOS prompt type **A:** and press **Enter**.
5. At the **A:** prompt, type:

```
copy pegserv.exe c:\service
```

and press **Enter**. Where **service** is the directory you created to contain the program files.

The program is copied to **c:\service**

Make sure that the serial interface configuration on the PC is set up as follows:

Datacom-Configuration

Parameter	Serial
Transmission Rate (BPS)	9600
Word Length (bits)	8
Stop-Bits	1
Parity	None
%ON /%OFF Pacing	Off
CTS Line	Regard
DSR Line	Regard
DCD Line	Ignore
Power to Interface	Off

Connecting the PC to the Monitor

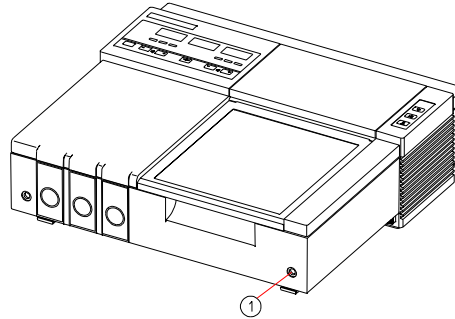

Figure 4-2 Service Socket

Connect the cable from the COM1 port of the PC to the service socket (1).

Loading the Service Program

1. Switch on both the monitor and the PC.
2. Load the program by doing one of the following:
 - If the program files are contained in a directory, change to that directory and enter:

```
pegserv
```
 - If you want to load the program from drive **A:** (or another drive)
 - i. Insert the program disk into drive **A:**
 - ii. Change to drive **A:** and enter:

```
pegserv
```
 - If you are using Windows 98/ NT: Start the service program by double-clicking on the pegaserv icon or on the filename pegaserv-exe
3. The program is now loaded and ready for use.

Using the Service Program

When the program has been loaded onto your PC, the main menu is displayed. (If the menu is not displayed, an error message is displayed along the bottom of the screen.)

Main Menu

```
-----  
Series 50 Fetal Monitor Configuration and Service Software Rev A.nn.nn  
-----  
Main Menu  
-----  
Configuration Settings  
Recorder Adjustments  
Service Menu  
Exit  
  
MESSAGE:  
Select with >cursor keys< or >E, S, D, X< then press <ENTER> to execute!!
```

To select an item from the menu, move the cursor to the item you require and press **Enter**. Use the **▲**, **▼**, **◀**, **▶** keys on the keypad, or the **E**, **S**, **D** or **X** keys to move the cursor.

While the service program is working, messages maybe displayed along the bottom of the screen. For example:

Reading Recorder Adjustments from the Monitor.

Reading Serial Number from the Monitor.

Clearing the Error Log.

Configuring the Monitor

```
-----  
Series 50 Fetal Monitor Configuration and Service Software Rev A.nn.nn  
-----  
Configuration Setting:  
-----  
Function      :      Actual Setting is      Select  
Paper Scale  :      US                      US      EU  
Time Format   :      AM/PM                   AM/PM  24h  
Date Format   :      US                      US      EU  
IUP Scale    :      mmHg                     mmHG   kPA  
  
MESSAGE:  
Select with >cursor keys< or >E, S, D, X< then press <ENTER> to execute!!
```

To change a setting:

1. Using the appropriate keys, move the cursor to the selection you require.
2. Press **Enter**.

To return to the Main Menu:

1. Move the cursor to **Return to Main Menu**.
2. Press **Enter**.

Example

On the screen above, the actual setting of the paper scale is **US**. To change this to **EU**, move the cursor to **EU** in the **Selection:** column and press **Enter**. The program will reconfigure the monitor for the European paper scale.

Note— The actual settings on your monitor may be different from those shown.

Adjusting the Recorder The Recorder Heat-Adjust is to compensate for different tolerances in the paper.

```

-----
Series 50 Fetal Monitor Configuration and Service Software Rev A.nn.nn
-----

Recorder Adjustments:
-----

Recorder Heat Adjust: Actual Value is:      |
                    Selected Value is      |
                                           |
                                           v
                    |.....|
                    Min      Max
Recorder Zero Adjust: Actual Value is:      |
                    Selected Value is      |
                                           |
                                           v
                    |.....|
                    Left  Right

Return to Main Menu

MESSAGE:
Select with >cursor keys< or >E, S, D, X< then press <ENTER> to execute!!
    
```

To change a setting:

1. Using the appropriate keys, move the cursor to the selection you require.
2. Press **Enter**.

To return to the Main Menu:

1. Move the cursor to **Return to Main Menu**.
2. Press **Enter**.

Example

On the screen above, the actual value of the **Recorder Zero-Adjust** is closer to the left side. If this is not printed exactly on **20** on the Toco channel, then you must realign the **Selected Value is:** to the right or to the left and then press **Enter**. The program will adjust the recorder accordingly.

Note— The actual values on your monitor may be different from those shown.

Service Menu

```

-----
Series 50 Fetal Monitor Configuration and Service Software Rev A.nn.nn
-----

                          Service Menu
-----

Serial Number       : 2948G00010
Software Revision   : A.02.03

      Cyclic Test
      Read options
      Read ErrorLog
      Clear ErrorLog
      Write Ser.nr./Set Options
      Fetal Heart Rate Alerting
      Return to Main Menu

MESSAGE:
Select with >cursor keys< or >E, S, D, X< then press <ENTER> to execute!!

```

To select an item from the menu, move the cursor to the item you require and press **Enter**. However, before you select **Cyclic Test**, connect ultrasound, Toco and DECG transducers to the monitor.

Note— The serial number and software revision of your monitor may be different from those shown.

Running the Cyclic Test

This runs a continuous Self Test. Any errors are written to the Error Log and can be read using **Read ErrorLog**. Press any key to stop the test and return to the Service Menu.

```

-----
Series 50 Fetal Monitor Configuration and Service Software Rev A.nn.nn
-----

      CYCLIC TEST is started
      It starts a continuous self test of the monitor

      Press any key to stop this test
      Read ErrorLog to see the errors that occurred while self testing

MESSAGE:

```

Note— During the test, the keys on the front panel are disabled.

Reading the Options

This lists the options installed on the monitor. Press any key to return to the Service Menu.

```
-----  
Series 50 Fetal Monitor Configuration and Service Software Rev A.nn.nn  
-----  
  
Implemented Options :  
  
- Fetal Movement Profile  
- External Twin Monitoring  
  
MESSAGE:  
Press any KEY to continue!
```

Note— The options on your monitor may be different from those shown.

Reading the Error Log

This displays the error log. (See -44 for the list of error log messages.)

```

> PAGE 1 <                               Errorlog of : 2948G00010

Err. Count 1st Date+Time last Date+Time
Code nnnn yy/mm/dd HH:MM yy/mm/dd HH:MM
|-| |--| |-----|-----| |-----|-----|

Use >W< to Write ErrorLog Data to File >ErrLog.DAT<
use CursorKey >Down< or >X< to see next Page, <ENTER> to leave

```

Up to 16 error messages can be displayed on a screen. To see the next or previous screen, use the ▲ or ▼ keys on the keypad, or the **E** or **X** keys. At the end of the Error Log, **No more Data available** is displayed.

Press **SHIFT** and **PrtSc** to print a page on LPT1.

Press **Enter** to return to the Service Menu.

To write the error log data to a file, press the **W** key. The data is then stored as **ERRLOG.DAT** in the directory containing **PEGSERV.EXE**. The data is stored as ASCII characters, and therefore the file can be printed using the DOS Command **print ERRLOG.DAT**. The file is overwritten each time you press the **W** key.

Printing the Error Log

To print the error log, complete the following steps:

1. Disconnect all transducers from the monitor and disconnect or switch off Telemetry.
2. Switch on the recorder.
3. Press **F.△** and **Test** at the same time:
 - **C01** is shown in the US1/US display.
 - **0** or **1** is shown in the Toco display.
4. Press **F.△** again to select the Service Function Menu:
 - **A01** (Print the Error Log) is shown in the US1/US display.
5. Press **↔** to print the error log. The display shows: **nnn nnn nnn**

The following table lists the error log and permanent test functions, and their corresponding menu numbers.

Table 4-4 Service Function Menu Numbers and Error Log Functions

Menu No.	Function
A01	Print the Error Log
A02	Clear the Error Log
A03	Start the Permanent Test

503	0001	91/05/12 17:33	91/05/12 17:33
510	0010	91/05/12 17:36	91/05/17 10:45
504	0001	91/05/12 17:33	91/05/12 17:33
506	0010	91/05/12 17:36	91/05/17 10:45
FIC			
C1C4	0001	91/05/12 17:33	91/05/12 17:33
C146	000A	91/05/12 17:36	91/05/17 10:45
<hr/>			
02/18/91	A.01.00	M1351A	3028G00203

Figure 4-3 Example of an Error Log

The error log lists the following (above the line and left to right):

- Error code.
- Number of times the error has occurred (the error counter uses hexadecimal notation).
- Date and time the error first occurred.
- Date and time the error last occurred.
- Factory Information Code (FIC).

The error log lists the following (below the line and left to right):

- Present date.
- Software revision number.
- Type of monitor.
- Serial number of monitor.

Note— **If the characters FIC are printed without other information, do not take any action. The information contained in the FIC section is additional information for internal use only. If you have a technical problem, contact the Philips support organization.**

Clearing the Error Log

To clear the error log, complete the following steps:

1. Disconnect all transducers from the monitor and disconnect or switch off Telemetry.
2. Press **F.⚠** and **Test** at the same time:
 - **C01** is shown in the US1/US display.
 - **0** or **1** is shown in the Toco display.
3. Press **F.⚠** again to select the Function Menu:
 - **A01** (Print the Error Log) is shown in the US1/US display.
4. Press **+** to select **A02** (Clear the Error Log).
5. Press **←→** to clear the error log.

The confirmation message **Are You Sure?** asks if you do want to clear the error log:

```
-----  
Series 50 Fetal Monitor Configuration and Service Software Rev A.nn.nn  
-----  
                          Service Menu  
-----  
  
Serial Number       : 2948G00010  
Software Revision   : A.02.03  
  
Cyclic Test  
Read options  
Read ErrorLog  
Clear ErrorLog           Are you sure?  
Write Ser.nr./Set Options  
Fetal Heart Rate Alerting  
Return to Main Menu  
  
MESSAGE:  
Select with >cursor keys< or >E, S, D, X< then press <ENTER> to execute!!
```

- Press the **Y** key to clear the error log
- or
- Press the **N** key.

You then return to the Service Menu.

Writing/Resetting the Serial Number and Setting the Options

Note— You can write the serial number to the monitor only if you have replaced the CPU Board with an exchange board. If you have accidentally entered the wrong serial number, you can reset it using an access code available from your Philips Medical Response Center or from the Philips Technical Marketing information "Softserver" page on the Philips Intranet. The serial number can only be written *once* to the exchanged board with each access code.

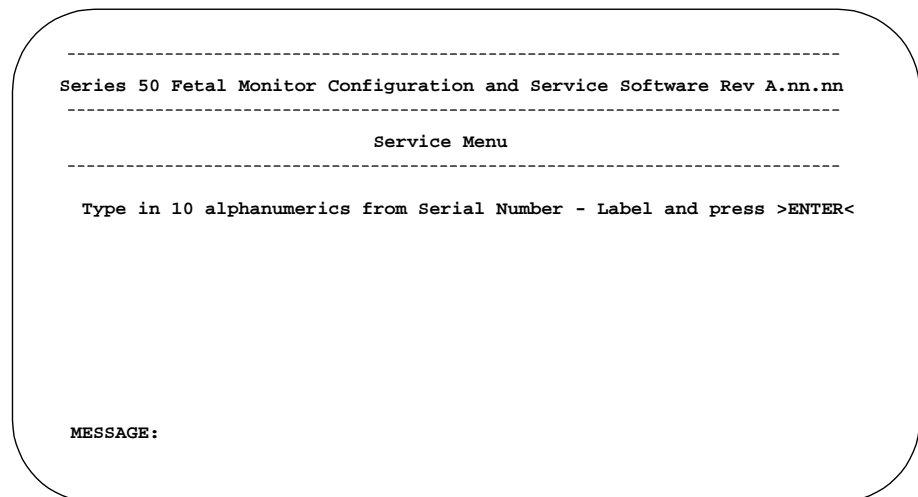

To write the serial number:

1. Using the keyboard, type in the serial number of the monitor. (This is printed on the side of the monitor.)
2. Press **Enter**.

A confirmation message asks if the serial number is correct:

- If it is correct, press the **Y** key.
- If it is not correct, press the **N** key and retype the serial number.

You then go to the **Set Options** screen.

To select an option:

```
-----  
Series 50 Fetal Monitor Configuration and Service Software Rev A.nn.nn  
-----  
Select Options according to the labels on the monitor  
-----  
  
Option:                Actual Setting is:    Selection:  
#C.01 TWIN:            OFF                    OFF  ON  
#C.02 FMP:            OFF                    OFF  ON  
Write Options  
  
MESSAGE:  
Select with >cursor keys< or >E, S, D, X< then press <ENTER> to execute!!
```

1. Using the appropriate keys, move the cursor to the selection you require.
2. Press **Enter**.

To write the options to the monitor and return to the Main Menu:

1. Move the cursor to **Write Options**.
2. Press **Enter**.

A confirmation message asks if the selected options are correct.

The following shows the resetting screen that is displayed when you need to reset the serial number:

```
-----  
Series 50 Fetal Monitor Configuration and Service Software Rev A.nn.nn  
-----  
  
NOTE: resetting the Serial Number is protected by Access Code  
  
Serial Number          :          3151G00026  
  
Type in 4 digit code from factory TME and press <ENTER>  
          >----<  
  
MESSAGE:
```

Contact your Philips Medical Response Center for your access code. Make sure you have the serial number of the original CPU board available.

FHR Alerting Enable/Disable

This screen enables you to enable or disable the fetal heart rate alerting.

In order to change this configuration, you must enter the access code. You can obtain this code from your Philips Medical Response Center or from the Philips Technical Marketing page "Softserver" on the Philips Intranet. (There is a specific access code to enable the alerting, and a specific access code to disable the alerting.)

To enable or disable the alerting, enter the specific code to enable or disable the alerting.

```
-----  
Series 50 Fetal Monitor Configuration and Service Software Rev A.nn.nn  
-----
```

```
NOTE: Changing the Alert Option is protected by Access Code !
```

```
Alert Option is ENABLED. Do you want to DISABLE the Alert option?
```

```
Press <Y> for YES or <N> for NO!
```

```
MESSAGE:
```

Error Log Messages

Table 4-5 Error Log Messages

Message	Location of Error and Solution
Err 18	Incorrect type of paper loaded (same as Err PAP). <i>Replace with recommended paper.</i>
Err 19	Battery low or empty of charge (same as Err bAt). <i>Change the batteries as soon as possible.</i>
Err 70	Modem not responding. <i>Modem is either not installed, incorrectly installed, faulty or not an approved model.</i>
Err 77	Error during transmission of data. <i>Probably due to external sources. Retransmit the data.</i>
Err 500	General failure - no specific location. <i>See the Troubleshooting Flowchart in Chapter 8.</i>
Err 501, 513	Front End Board (Single Ultrasound model). <i>See the Troubleshooting Flowchart in Chapter 8.</i>
Err 502	Power Supply Board. <i>See the Troubleshooting Flowchart in Chapter 8.</i>
Err 503	CPU Board. <i>See the Troubleshooting Flowchart in Chapter 8.</i>
Err 510	Recorder Board. <i>See the Troubleshooting Flowchart in Chapter 8.</i>
Err 511	Front End Board (Dual Ultrasound model). <i>See the Troubleshooting Flowchart in Chapter 8.</i>
Err 512	Intrapartum Board. <i>See the Troubleshooting Flowchart in Chapter 8.</i>
Err 531	Combined Interface Board. <i>See the Troubleshooting Flowchart in Chapter 8.</i>
Err 532	Modem Interface Board. <i>See the Troubleshooting Flowchart in Chapter 8.</i>
Err 601	Paper feed. <i>See the Troubleshooting Flowchart in Chapter 8.</i>
Err 602	Incorrect type of paper. <i>Load paper with the correct scale or change the setting.</i>
Err 610	No loudspeaker, or fuse has blown. <i>See the Troubleshooting Flowchart in Chapter 8.</i>

Table 4-5 Error Log Messages

Message	Location of Error and Solution
Err 611	Wrong loudspeaker impedance. <i>See the Troubleshooting Flowchart in Chapter 8.</i>
Err 800	Software error: checksum wrong or download incomplete. <i>Reload the software.</i>
Err 820	Upgrade Key is for a different type of monitor. <i>Use the correct key.</i>
Err 888	No software upgrade done. <i>Disconnect transducers and telemetry first.</i>

Error Log Messages

Setting Time, Date, and Paper Speed

Time and Date

To set the time and date:

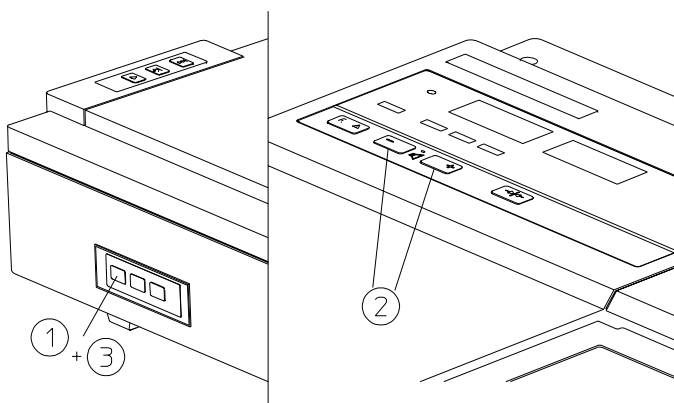







Figure 5-1 Time and Date Paper Speed Controls

1. Press  to display the current time. The hour is shown in the US1/US display and the minutes in the Toco display. The US1/US display flashes to show that the hour can be changed.
2. Press  or  to set the hour. Press and hold the key to change the setting more quickly.
3. Press  again and the Toco display flashes to show that the minutes can be changed.
4. Press  or  to set the minutes.
5. Repeat steps 3 and 4 to set the month, day and year, and to return to the normal display.

In North America, the month is shown in the US1/US display and the day in the Toco display. In other countries, the day is shown in the US1/US display and the month in the Toco display.

You also return to the normal display automatically if you wait eight seconds without pressing a key. When you return to the normal display, the new time and date are set, and the time, date and paper speed are printed on the paper.

Paper Speed

To set the paper speed:

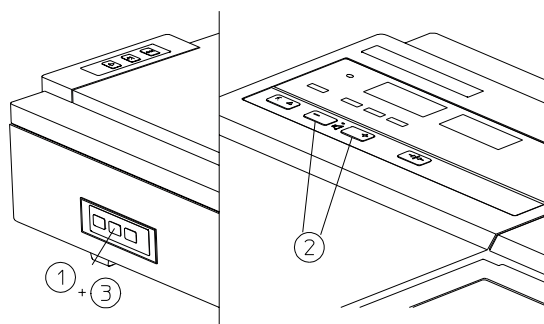





Figure 5-2 Paper Speed Controls

1. Press  to display the current speed.
2. Press  or  to set the speed.
3. Press  to return to the normal display.

You also return to the normal display automatically if you do not press any key for a few seconds. When you return to the normal display, the new paper speed is set, and the time, date, speed and monitoring modes are printed on the paper.

The paper speed can be 1, 2 or 3 cm/min. The default for North America is 3 cm/min; the default for other countries is 2 cm/min.

Note— The ACOG technical bulletin on FHR monitoring states that “*accurate pattern recognition is difficult if not impossible at 1 cm/min and that 1 cm/min is only recommended for more economic screening. When FHR abnormalities arise, the faster paper speeds will enhance FHR pattern recognition*”. In addition, since a change in paper speed will result in a change in the appearance of an FHR trace, care must be taken to ensure **ALL** monitors in your institution are consistently set at the same speed or speeds.

6

Theory of Operation

System Overview

The boards and their interconnections are shown in the following figure.

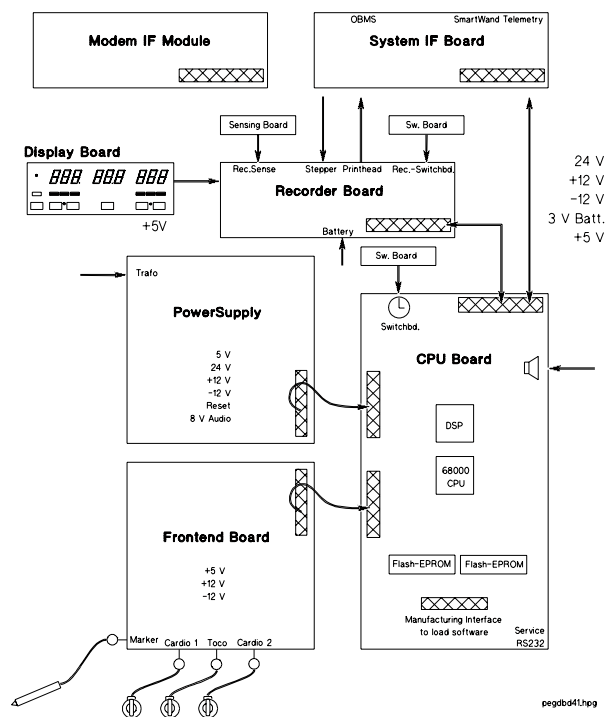

The CPU board, which has overall control of the entire system, contains flash EPROMs containing all the system software. The software for the Combined Interface Board (if one is fitted) is loaded from this ROM area. The signals from the transducers receive some analog conditioning on the Front End Board and are then digitized on the CPU Board. The CPU Board includes a digital signal processor. The results of the processing are distributed to the outputs (for example, the Recorder, “traffic lights” and Combined Interface Board).

Booting and Self Tests

The monitor carries out a basic test every time it is switched on, and then at periodic intervals while it is on. There are two types of test:

- Programs that check the hardware on each board.
- Programs that carry out checksums on the individual portions of code that are loaded from the Flash EEPROMs.

When the monitor is switched on, the initial reset generated by the power supply is fed to the CPU Board, where it is latched and passed to the other boards. Each board latches the reset to light its error LED. The LED can only be switched off by the CPU Board de-latching it.

All error LEDs are on at the start of the tests. If a hardware error is detected on a board, its error LED stays on and its error code is shown on the display. (The error code is the last three digits of the board's part number.) But note that if any element in the display chain is not working, the errors may not be displayed. If a board passes its test, the LED goes out, and the next board in the sequence is tested.

The Power Supply Board, Front End Board and Recorder Board have no processor and so are tested by the CPU Board.

The boards are tested in the following sequence:

1. CPU Board.
2. Power Supply Board.
3. Front End Board.
4. Recorder Board.
5. Combined Interface Board (if one is fitted).
6. Modem Interface Board (if one is fitted).

The processor on the CPU Board runs a self-test program from the Flash EEPROMs to test certain functions of the CPU Board:

- If the test fails, the red LED stays on and "Err 503" is displayed.
- If the test is successful, the red LED on the board goes out.

The current limits of the outputs of the Power Supply Board are then checked:

- If any currents are out of limits, "Err 502" is displayed. Note that this does not necessarily mean that the Power Supply Board is faulty (for example, a short on another board could be drawing too much current).
- If the test is successful, the red LED on the CPU Board is switched off.
- All other boards are then tested. The red LEDs on the Front End Board and the Recorder Board are lit for about 1 s, and then switched off when the test is successful.

The Combined Interface Board and the Modem Interface Board both have processors that test the interface board once the DMA control logic has been checked.

The CPU Board boots a test program from the ROM to the on-board Digital Signal Processor (DSP) program RAM. The DSP then runs it. The program tests the DSP and its associated components, and writes the results to the DSP RAM. The CPU reads the RAM to find out the exit status of the tests. If the test fails, the LED stays on and the error code is displayed.

The signal processing software is stored as two programs in Flash EEPROMs. This carries out US/US or US/ECG functions. The CPU Board transfers the US/US or US/ECG program from its Flash EEPROMs to the program RAM of the DSP.

All the time the monitor is on, the CPU Board checksums the signal processing software and the Flash EEPROMs at 1-minute intervals. If the tests fail, the system is reset and rebooted. And every 300ms, a watchdog ASIC is fed patterns by the CPU Board 68000. If the ASIC does not receive a pattern, it resets the system.

Front End Board

M1351A (M1353-66501 and M1353-66511)

The Frontend board (M1353-66501 – single, M1353-66511 - dual) contains the analog circuitry for measuring all the possible parameters of the M1351A. One IC on the board provides the US timing and window control. Each type of transducer has a specific mode resistor which is recognized by the M1351A when the transducer is connected to an input socket. In this way, the user can be warned if a wrong transducer is connected. The marker cable is also connected to the Front End Board.

The frontend boards used with software at Rev E and higher are triangular in shape, not rectangular.

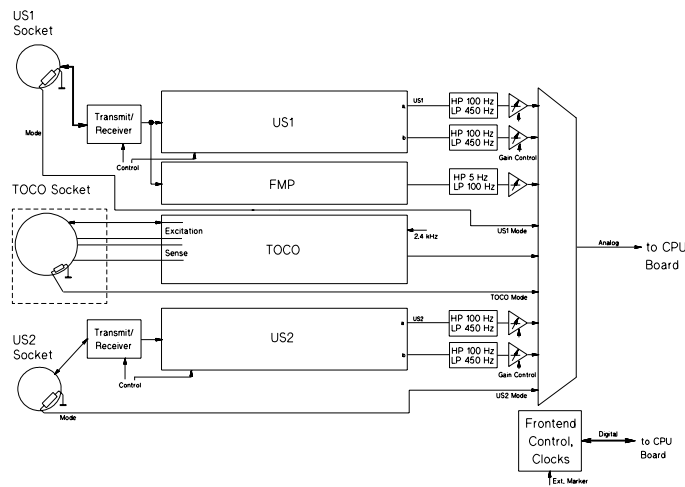

Ultrasound

The ultrasound transducer transmits 998.4kHz ultrasound bursts which are generated by the digital control ICs. The burst widths are controlled by software. The transmitter amplifier supplies $5V_{pp}$ at the Cardio sockets. The repetition rate is 3.2kHz. The received 998kHz signal is amplified by a high frequency amplifier with a gain of 120 and then split to provide a reference path **a** and a compare path **b**. The two demodulators **a** and **b** are independently controlled by software in their receive windows by the control ICs. The demodulated LF signals are bandpass filtered (100 to 450Hz) and amplified by a software controlled gain of 180 to 1860 in eight steps. The FMP-LF path is independently demodulated, bandpass filtered and amplified by a factor of 18.

Toco

The excitation voltage is a biphas 2.4kHz rectangular continuous wave with an amplitude of $5V_{pp}$. The frequency is generated in the control chip by dividing the 4MHz system clock. the sense input is amplified by 786 ($5\mu;V/V/mmHg$), rectified with a synchronous detector and lowpass filtered with a cut-off frequency of 7.5Hz.

M1353A (M1353-66512)

Used in monitors with serial number prefix $\leq 3652G$.

The Frontend board contains the analog circuitry for measuring all the possible parameters of the M1353A. An IC on the board provides the US timing and window control, and

controls the ECG. Each type of transducer has a specific mode resistor which is recognized by the M1353A when the transducer is connected to an input socket. In this way, different types of transducer can be used without the user having to recalibrate the system. The marker cable is also connected to the Frontend Board.

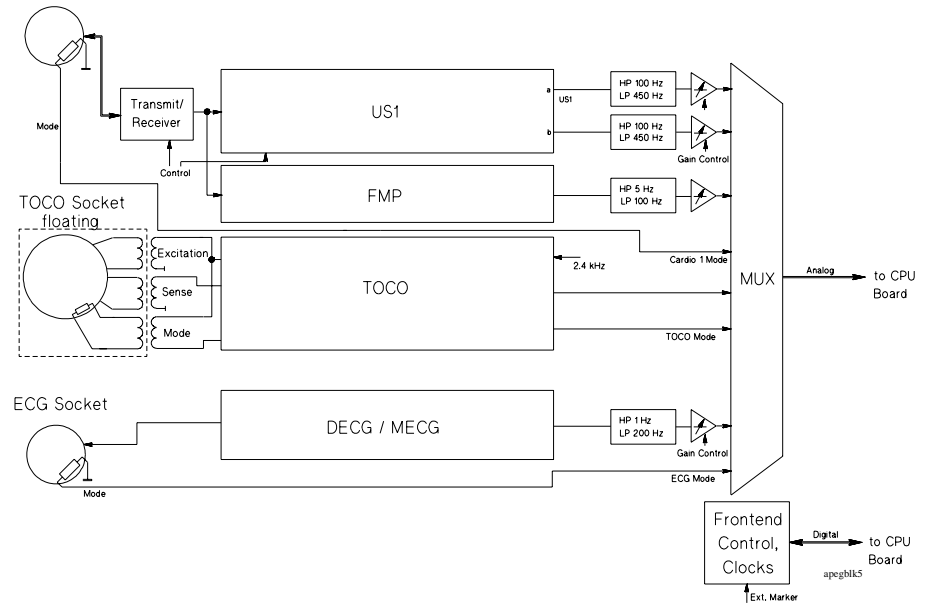

Frontend Board for M1353A (M1350-66517)

Used in monitors with serial number prefix $\leq 3720G$.

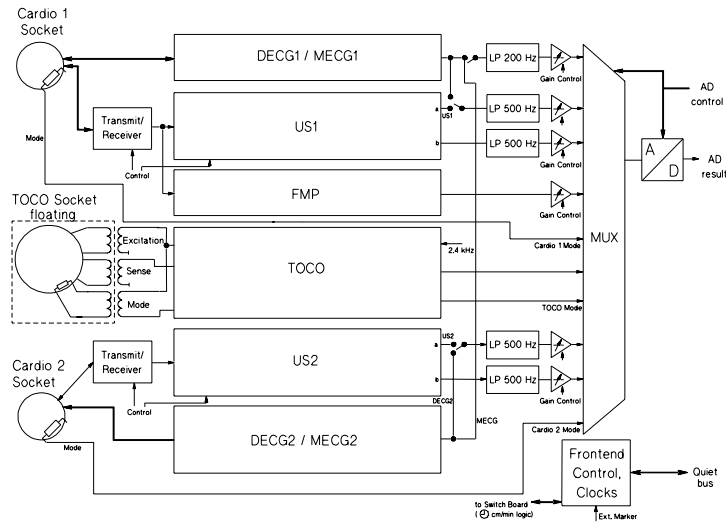

Figure 6-1 Frontend Board

The Frontend board contains the analog circuitry for measuring all the possible fetal parameters of the M1353A. The FOCUS ASIC on the board provide the US timing and window control, and controls the ECG.

Each type of transducer has a specific mode resistor which is recognized by the M1353A when the transducer is connected to an input socket. In this way, different types of transducer can be used without having to recalibrate the system.

ECG The FOCUS IC divides the 4 MHz system clock to generate a 181 kHz clock. A power stage generates the power clock for the ECG transducers. The ECG signal modulates the supply current of the transducer. The modulated current is detected, amplified and bandpass filtered (1 - 250 Hz). Block DECG/MECG1 is unused.

US The US transducer transmits 998.4 kHz ultrasound bursts which are generated by the FOCUS IC. The burst widths are controlled by software. The transmitter amplifier supplies 5 V_{pp} at the Cardio sockets. The repetition rate is 3.2 kHz.

The received 998 kHz signal is amplified by a high frequency amplifier with a gain of 120 and then split to provide a reference path **a** and a compare path **b**. The two demodulators **a** and **b** are independently controlled by software in their receive windows by the FOCUS IC. The demodulated LF signals are bandpass filtered (100 - 500 Hz) and amplified by a software controlled gain of 180 to 1860 in eight steps. The **FMP**-LF path is independently demodulated, bandpass filtered and amplified by a factor of 18.

TOCO The pins of the TOCO/IUP socket are electrically isolated, connected by three transformers (excitation, sense and mode). The excitation voltage is a 2.4 kHz square wave with an amplitude of 3.5V_{RMS}. The frequency is generated in the control chip by dividing the 4 MHz system clock.

The sense input signal is amplified by 93.75 (40μ;V/V/mmHg) or 750 (5μ;V/V/mmHg), rectified with a synchronous detector and lowpass filtered with a cutoff frequency of 7.5 Hz. All LF signals are multiplexed, sampled at either 1600 or 800 Hz, and A/D converted with 12-bit resolution.

The marker cable and the switch board are also connected to the Frontend board.

Power Supply Board (M1353-66502)

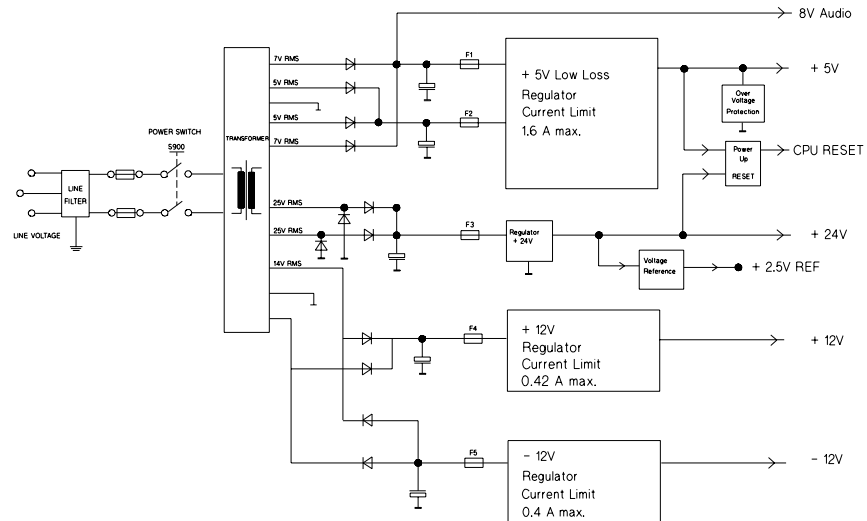

The Power Supply Board operates as a linear regulated power supply with rectifier, capacitor and regulator. It generates the following voltages:

Regulated dc: $\pm 12\text{V}$, $+5\text{V}$ and $+24\text{V}$

Unregulated dc: $+7\text{V}$ to $+12\text{V}$

$\pm 12\text{V}$ and $+5\text{V}$ have an electronic short circuit current limit. The $+24\text{V}$ dc regulator works independently from the others. The $+24\text{V}$ are used for the thermal printhead fed through the recorder IF-board. The internal $+2.5\text{V}$ reference voltage is generated from the $+24\text{V}$, so if the 24V section is inoperative, the rest of the power supply won't work. The -12V regulator also needs the regulated $+5\text{V}$ to work correctly. The reset (open collector output) is active low, when either the $+5\text{V}$ is lower than $+4.6\text{V}$ or the $+24\text{V}$ is lower than $+14.8\text{V}$. If the $+5\text{V}$ is higher than 6.2V (this can be caused by any failure of the power supply or the other boards) the over-voltage protection is triggered and pulls down the voltage to about 3.4V . This state can only be relieved by switching the monitor off and on (if the failure isn't still remaining).

CPU Board (M1353-66503 and M1353-66513)

CPU Board M1353-66503

This board works with the 4 ohm loudspeaker and is used in:

- M1351A monitors with serial number prefix $\leq 3604G$.
- M1353A monitors with serial number prefix $\leq 3605G$.

CPU Board M1353-66513

This board works with the 8 ohm loudspeaker and is used in:

- M1351A monitors with serial number prefix $\geq 3651G$.
- M1353A monitors with serial number prefix $\geq 3652G$.

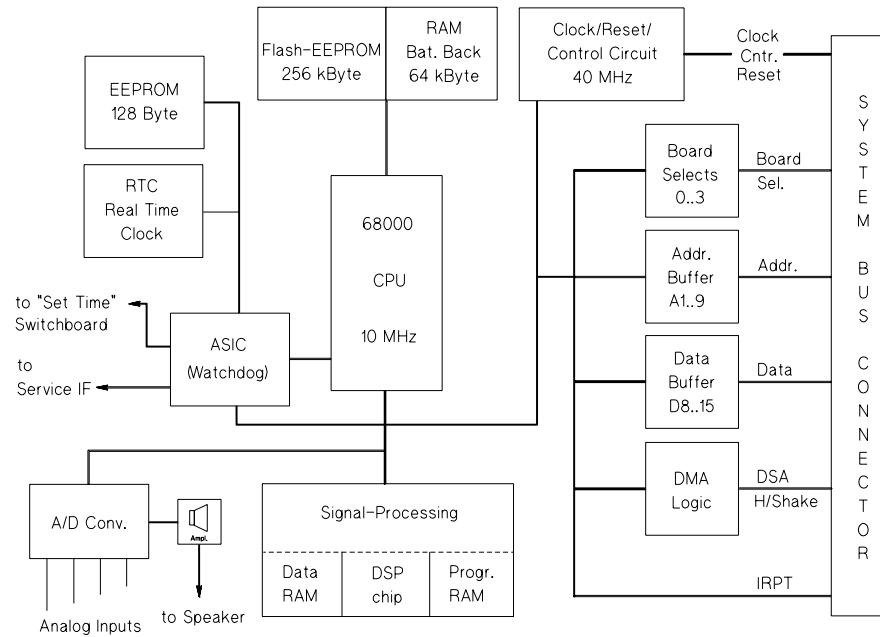

apeghk2

The Central Processor Unit (CPU) Board is the heart of the system and controls most other boards. The 68000 microprocessor and associated support ICs provide system functions; the bus control section controls the system bus. The board contains two Flash EEPROMs which contain all the system software. The board includes the following sections:

- Microprocessor Section:
 - 68000 microprocessor.
 - Flash EEPROMs containing all system software and a boot program allowing software upgrades via the Service Connector.

- CMOS RAM memory, backed by a battery to store short time device settings etc.
 - A non-volatile EEPROM memory for permanent device and user settings.
 - A real-time clock, battery-backed and power-fail protected. The processor has access to all clock registers.
 - The multiplexer ASIC contains a watchdog function which monitors the operation of the microprocessor and restarts the system if it is not served at a constant rate.
- AD/DA Section:
 - After system startup, the CPU starts the A/D control chip, which divides the signal from the clock circuit and generates an interrupt every 2.5 ms.
 - The 68000 on the CPU Board then programs the multiplexer to select the analog channels for A/D conversion: the analog/digital conversion of up to eight channels is done by the multiplexer without further intervention by the CPU. A/D conversion is by successive approximation. After the next interrupt, the CPU reads the results stored in registers within the multiplexer. The multiplexer also receives values from the CPU for audio output.
 - All LF signals are multiplexed, sampled at either 1600 or 800Hz, and A/D converted with 12-bit resolution.
- Digital Signal Processing Section:
 - Signal processor and RAM.
 - DMA logic.

DSP software rebooted when the US2 channel socket is connected/disconnected.
- Bus Control Section:
 - Address and data bus control chips.
 - Board select logic to access all system boards.
 - DMA circuits to allow DMA access via the system bus to the Combined Interface.
 - A crystal quartz oscillator and related circuitry provide several local and bus clock frequencies.
- Service Interface: An RS232 serial interface is provided for use during production and service. Connection is via a stereo phone jack on the front panel.
 - Serial interface for option and software upgrades.
 - Settings and configuration via an external computer.

Display Board (M1350-66520)

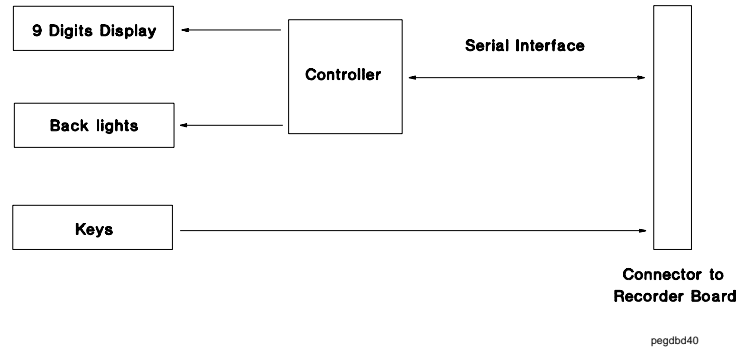

The display board consist of the following main parts:

- Keys
- Display Controller
- Backlights
- LEDs

Signals at the keys are fed to the recorder board via the ribbon cable and are sampled by the controller. Display data is loaded from the recorder board to the display controller ASIC via a serial data link. The controller multiplexes this data to the LEDs and backlights. The multiplexer clock is served by the recorder board. The clock speed is 3.2kHz to avoid interference between the US channel and the display multiplexer.

Recorder Interface Board (M1353-66510)

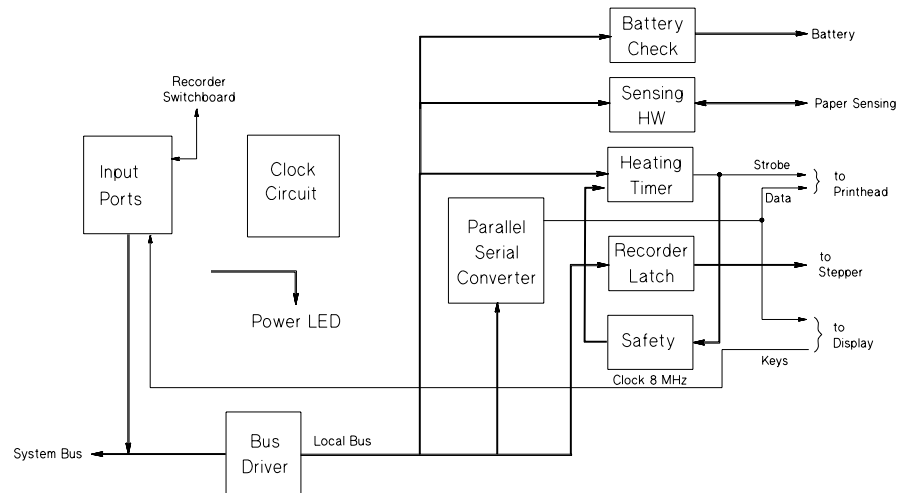

apcgbk3

The Recorder Board provides the interfaces to the recorder and the display. The recorder interface consists of:

- The parallel/serial converter for the thermal array data.
- A heating timer to control the heating pulse for the thermal array. The voltage from a thermistor on the thermal array is A/D converted and the CPU programs the heating timer with a value which compensates the ambient temperature.
- The recorder sensing hardware consists of a reflective light sensor that detects the black marks on the paper and paper out. A battery supervisor circuitry checks for valid battery voltages, and this is read by the CPU Board. The display interface uses the same parallel/serial converter as the recorder. The board also contains test hardware which is not shown in the diagram.
- +24V is blocked by capacitor and supplied to the thermal printhead.

Interface Boards

The interface boards available are:

- The Combined Interface Board
- The Modem Interface Board.

Combined Interface Board

There are two boards available; the M1353-66531 and M1353-66531E. Both boards process analog input signals from Philips telemetry systems (for example, the M1310A), and send heart rate, Toco, mode and status information to Philips OB systems, such as OB TraceVue.

Both boards receive signals from:

- A Barcode Reader.

Additionally, the M1353-66531E board also receives:

- Signals from a maternal NIBP Monitor.
- FMP from a Series 50 Telemetry M1310A
- Ext. Marker from a Series 50 Telemetry M1310A.

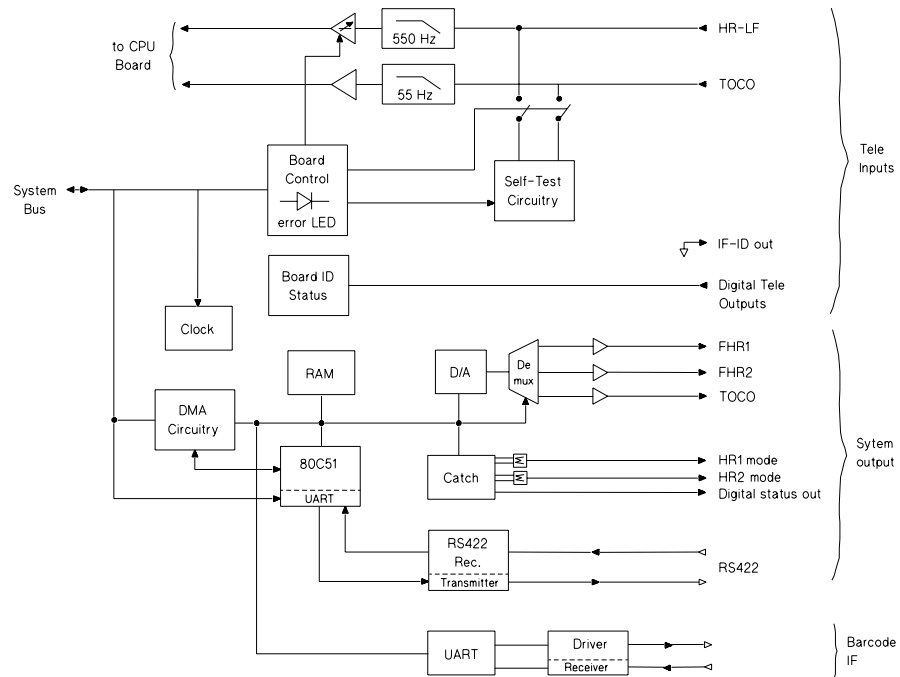

Figure 6-2 Combined Interface Board M1353-66531 replaced by version with RS232 interface)

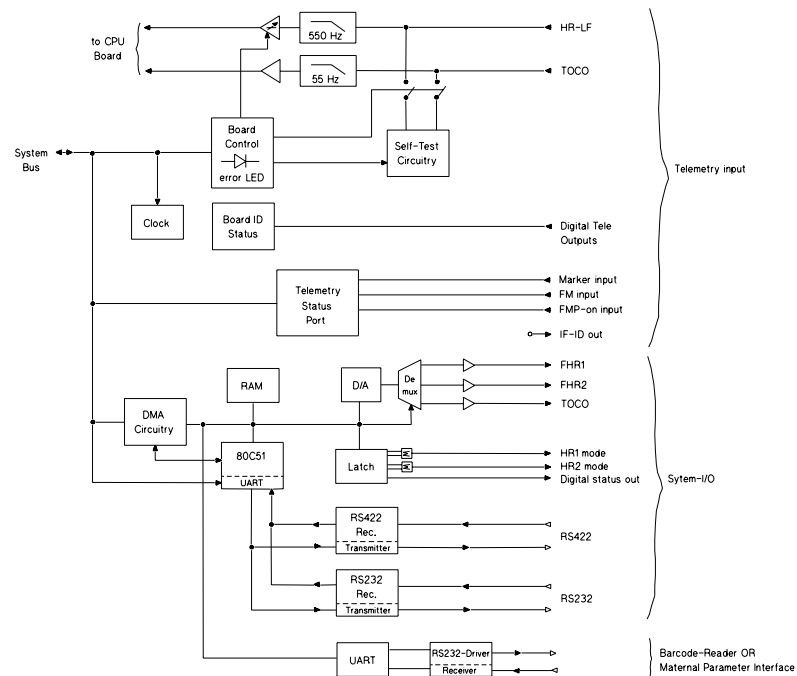

Figure 6-3 Combined Interface Board M1353-66531(E)

Both the M1353-66531/66531E boards include the following sections:

- Analog Signal Filter Section:
 - An analog input for FHR, US LF or DECG, with low pass filter and variable gain amplifier.
 - An analog input for TOCO/IUP with low pass filter.
 - The analog signals are fed to the A/D convertor on the CPU Board.
- Digital Clock and Control Sections:
 - Board ID latch.
 - Status input lines.
 - Control latch.
 - Bus control and clock circuits.
- Calibration and Self Test Section:
 - Calibration and reference circuits.
 - System controlled test signal generation.
 - Analog switches to apply reference voltages and test signals to the telemetry inputs.

- System Section:
 - This section is controlled by an 80C51 microcontroller. The communication between this controller and the CPU on the CPU board is done by dumps every 250 msec. The CPU also boots the software for the 80C51 controller into the ROM during startup.
 - The analog voltages heart rate 1, heart rate 2 and TOCO are generated by a DAC which feeds three sample and hold buffers via a multiplexer.
 - The latch stores mode and status information. Status information is passed to the output as a logic signal. Mode information is a sum of logic signals and appears as an analog voltage at the output.
 - The 80C51 UART, RS422 receiver/transmitter form a bi-directional RS422 interface for OB TraceVue connection. *Combined Interface Board M1353-66531E only*: The RS232 receiver transmitter forms a bi-directional RS232 interface for OB **TraceVue** connection.
- Barcode Reader or Maternal NIBP Monitor Section:

The Combined Interface Board M1353-69531 provides the interface to a Barcode Reader. The Combined Interface Board M1353-69531E provides the interface to a maternal NIBP Monitor or a Barcode Reader. (See Chapter 10 for details on how to configure the Monitor for either a Barcode Reader or a maternal NIBP Monitor). A second UART with driver/receiver form a $\pm 12V$ RS232 interface for the barcode reader or the maternal NIBP Monitor. Data is also processed by the 80C51 processor.

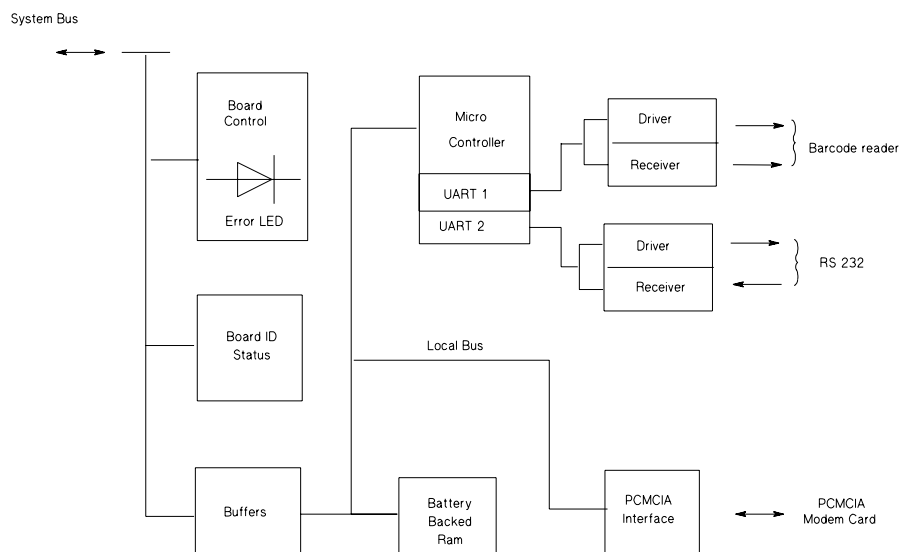

Figure 6-4 Modem Interface Board M1353-69532

Modem Interface Board

The M1353-66532 modem interface board allows the storage and the transmission of fetal trace data via a telephone line. The interface board enables the fetal monitor to form part of a remote monitoring system, consisting of:

- A Transmitter (Series 50 A/IP Fetal Monitor with Modem Interface Option).
- Receiver (OB **TraceVue** system).

The system also receives information from:

- A Barcode Reader.

The M1353-66532 Modem Interface board includes the following sections:

- Board Control section:
 - Board control latch
 - Board ID and status circuit
 - Bus buffers and clock recovery circuits
- System Section:
 - This section is controlled by an M37702 microcontroller. The communication between this controller and the CPU on the CPU board is done by dumps every 250 msec. The CPU also boots the software for this controller into the RAM during startup.
 - When a PCMCIA card is plugged in, it will be recognized and activated by the PCMCIA interface, specified by PCMCIA card standard 2.01. The controller deactivates this interface after the removal of the PCMCIA card. The modem commands and data are controlled by the M37702 microcontroller.
- Barcode Reader Circuits
 - The first controller UART and the driver/receiver form an RS232 interface for the Barcode Reader. Barcode data is processed by the controller.
- The auxiliary RS232 serial port (no Philips software available).

Tests and Error Messages

Service Philosophy

Any errors produced are marked on the trace paper with the symbol  and a specific error message is shown on the monitor display. In addition, the errors are reported on the system error log (see page 38 for instructions on how to print the error log). Read the error messages and system error log to determine whether the fault lies in the hardware or firmware. These problems can be repaired by board replacement or unit exchange. Do not attempt component-level board repair.

Overview of the Service Tests

The system contains resident tests to enable monitoring of system status and errors that occur.

- Power-On Self Test (see page 65)
This is invoked whenever the system is switched on.
- Performance Assurance Tests
 - Parameter Test (see page 68)
This checks the processing of the signal from the transducers.
 - Quick Test (see page 66)
This checks the display, recorder and complete instrument hardware and software.
- Service Tests
These are invoked by connecting the monitor to a PC and using a software service tool to assess, test and configure the system.
 - Cyclic Test (see page 35)
 - Permanent Test (see page 70)
- Safety Tests
These test the electrical safety of the monitoring system and must be carried out after upgrades and repairs. You must use a safety testing tool.
 - Instrument Safety Test (see page 105)
 - System Safety Test (see page 105)
 - Safety Test Blocks (see page 100)

Performance Assurance Tests

Self Test

The monitor automatically performs a basic-level self test when you switch it on. There are two possible types of error that you might see. A fatal error prevents the monitor from functioning. A non-fatal error allows you to continue to work but warns you of a problem that must be resolved swiftly.

- If a non-fatal error occurs (for example, if the batteries are low):
 - An error message is displayed for approximately 13 seconds.

- **Err xxx**  , time and date are printed on the paper after 13 seconds, and then every 10 minutes.

(**xxx** is the number of the error message.)

Switch the monitor off and then on, and if the error occurs again refer to Chapter 8, “Troubleshooting Flowcharts.” (If the recorder is not on when the monitor is switched on, **Err xxx  , time and date are printed when it is switched on subsequently.)**

- If a fatal error occurs (for example, if a board is defective):
 - An error message is displayed for approximately 13 seconds.
 - After 13 seconds, the monitor will try to restart.

If the error occurs again refer to Chapter 8, “Troubleshooting Flowcharts.”

Quick Test

This tests the display, recorder and monitor hardware and takes approximately 15 seconds. To carry out the test:

1. Switch on the monitor and the recorder.
2. Disconnect any transducers from the monitor (and if appropriate, switch off and disconnect the telemetry receiver).
3. Press **Test** once.

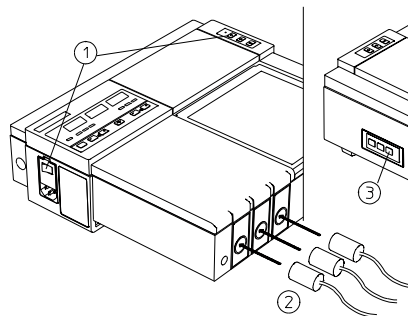

Figure 7-1 System Test Controls

Check that:

- The displays flash alternately with the indicators and lamps for approximately 13 seconds.
- The **Err xxx** on/off light blinks in time with the display.
- A test pattern is printed on the paper.

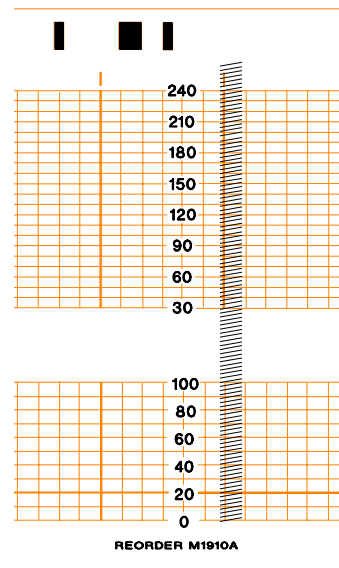



Figure 7-2 Test Pattern

4. Check the dots in the test pattern to ensure all the heating elements on the printer head are operational. (Dots printed on the colored grid lines may appear light, but this is not considered to be a fault.) Check that:
 - No more than 20 dots are missing over the width of the paper.
 - No more than 2 adjacent dots are missing.
 - No dots in the mode annotation are missing.

If any of these checks fail, replace the thermal print head (see -151). The paper speed is automatically set to 3 cm/min during the test and then reset to its previous value afterwards.

If an error occurs:

- An error message is displayed for ten seconds.
- **Err xxx** , time and date are printed on the trace after ten seconds and then every ten minutes.

(xxx is the number of the error message.)

To stop the error annotation printing, switch the monitor off and then on. If the error is repeated, refer to Chapter 8, “Troubleshooting Flowcharts.”

Parameter Test This tests the signal to and from the transducer, but not the transducer itself. To carry out the test:

1. Switch on the monitor and the recorder.
2. Connect the appropriate transducer to each socket.
3. Press and hold **Test**.

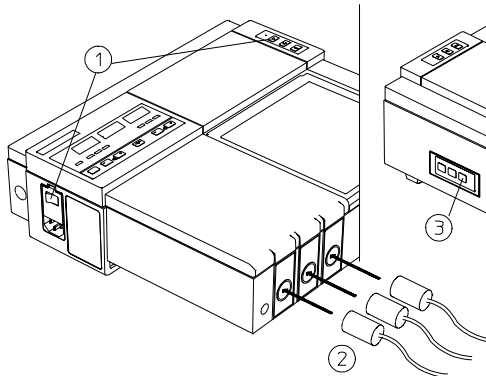



Figure 7-3 Parameter Test Controls

The correct monitor response for each signal is given in the following table. If your response is significantly different, refer to Chapter 8, “Troubleshooting Flowcharts.”

Table 7-1

Signal	Correct Monitor Response
US/US1	190 is displayed and printed, the Signal Quality Indicator is green, and the fetal heartbeat is heard from the loudspeaker.
Toco	A signal alternating between 10 and 60 is displayed and printed.
DECG	200 is displayed and printed, the Signal Quality Indicator is green, and the fetal heartbeat is heard from the loudspeaker.
MECG	120 is printed.
US2	170 is displayed and printed, the Signal Quality Indicator is green, and the fetal heartbeat is heard from the loudspeaker.





If an error occurs:

- An error message is displayed for ten seconds.
- **Err xxx** , time and date are printed on the paper after ten seconds, and then every ten minutes.
(**xxx** is the number of the error message.)

To stop the error annotation printing, switch the monitor off and then on.

Operator Error Messages

Table 7-2 Operator Error Messages

Message	Display	Cause and Solution
Err 1 ¹	US/US1	Wrong transducer in the US1/US socket. <i>Connect the correct transducer.</i>
Err 1 ¹	US2/ECG	Wrong transducer in the US2/ECG socket. <i>Connect the correct transducer.</i>
Err 2 ¹	Toco	Wrong Toco transducer in the Toco socket. <i>Connect the correct transducer.</i>
Err 4 ¹	US ECG/US2	US/MECG Combi transducer not allowed. <i>Remove the transducer.</i>
Err 9	US1/US Toco US2/ECG	Invalid Telemetry mode. <i>Check the cable from the Telemetry Receiver and, if necessary, replace it. Check all connections.</i>
Err 16	US1/US Toco US2/ECG	Wrong pairing of Telemetry and transducers. <i>Either disconnect the transducers or switch off the Telemetry Receiver.</i>
nop	ECG	No contact or poor contact between any of the contacts of the system. Check all connections, especially the legplate connector electrode. <i>Use a new spiral electrode.</i>
Err PAP ² / Err 18		Incorrect type of paper loaded. <i>Replace with recommended paper.</i>
Err bAt  ³ / Err 19		Battery low or empty of charge. <i>Change the batteries as soon as possible. If you do not change the batteries, your specific settings will return to their default values when the monitor is switched off (for example, the date is set to 4.4.44).</i>
Error 601  ⁵		Paper speed. Check that correct paper is used. Check the speed by timing how long it takes for the paper to advance 1cm: <i>60 seconds = 1cm/min</i> <i>30 seconds = 2cm/min</i> <i>20 seconds = 3cm/min</i> Contact your Philips Service Engineer or Response Center if the speed is incorrect.
Err PAP 30-240  ⁴ Err 602 ⁵		Incorrect type of paper loaded. <i>Load paper with 50-210 scale or change the paper format setting of the monitor.</i>
Err PAP 50-210  ⁴ Err 602 ⁵		Incorrect type of paper loaded. <i>Load paper with 30-240 scale or change the paper format setting of the monitor.</i>
Err 70 ⁶		Modem not responding. <i>The Modem is either incorrectly installed, faulty or not an approved model.</i>
Err 77 ⁶		Telephone transmission failure. <i>Line busy or faulty, wait short time and send information again.</i>
Err 532 ⁶		Modem Interface board failure. <i>Board failure will prevent data transmission from taking place and may possibly generate Err 70 and Err 77 messages.</i>

1. See the *Instructions for Use* for your monitor for the types of transducers that can be connected.
2. Displayed for ten seconds after the wrong paper is detected.
3. Displayed for ten seconds when the monitor is first switched on.
4. Printed every ten minutes.
5. Printed every three pages.
6. Only applicable with the Modem Interface Module fitted.

Permanent Test

Note This is similar to the Cyclic Test described on page 35.

To carry out the Permanent Test:

1. Disconnect all transducers from the monitor and disconnect or switch off Telemetry.
2. While pressing **F.▲** press **Test**:
 - **C01** is shown in the US1/US display.
 - **0** or **1** is shown in the Toco display.
3. Press **F.▲** again:
 - **A01** is shown in the US1/US display.
4. Press the **+** key twice:
 - **A03** is shown in the US1/US display.
5. For each signal to be tested, connect a transducer to the corresponding socket within 15 seconds: US1/US, Toco, US2, and/or ECG.
6. Connect the Remote Event Marker.
7. While pressing the button on the marker, press the Toco Baseline Key. The test runs for as long as the button on the marker is pressed.

FSpO₂

There are no operator error message for FSpO₂. If no FSpO₂ annotation is printed on the trace, you should refer to the troubleshooting flowchart -93.

Troubleshooting Flowcharts

Introduction

Troubleshooting is based on the interpretation of the error messages written on the display and in the systems error log. See page 69 for a list of Operator Error Messages. For a list of error log messages and details of how to print the error log, refer to -38. There are cases, however, when no error message, or the nature of the problem precludes the implementation of any automatic testing schemes. This chapter directs you towards the problem in a schematic approach. This method of troubleshooting may lead you to discover a blown fuse or a power supply failure.

Error 500: General Failure

Warning

The following task requires that the power be on while the cover is removed. Proceed only with extreme caution. Failure to do so can result in serious injury.

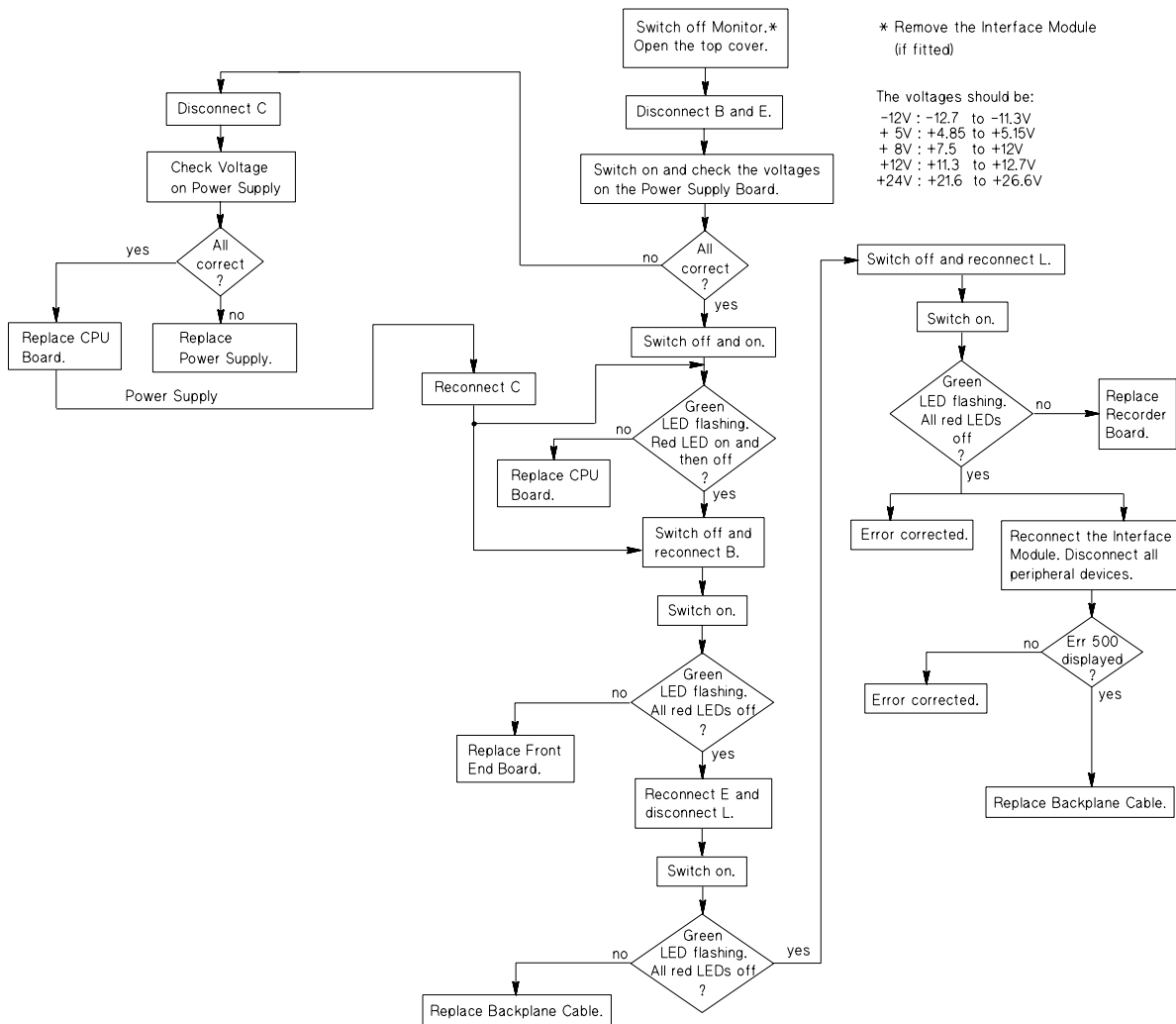
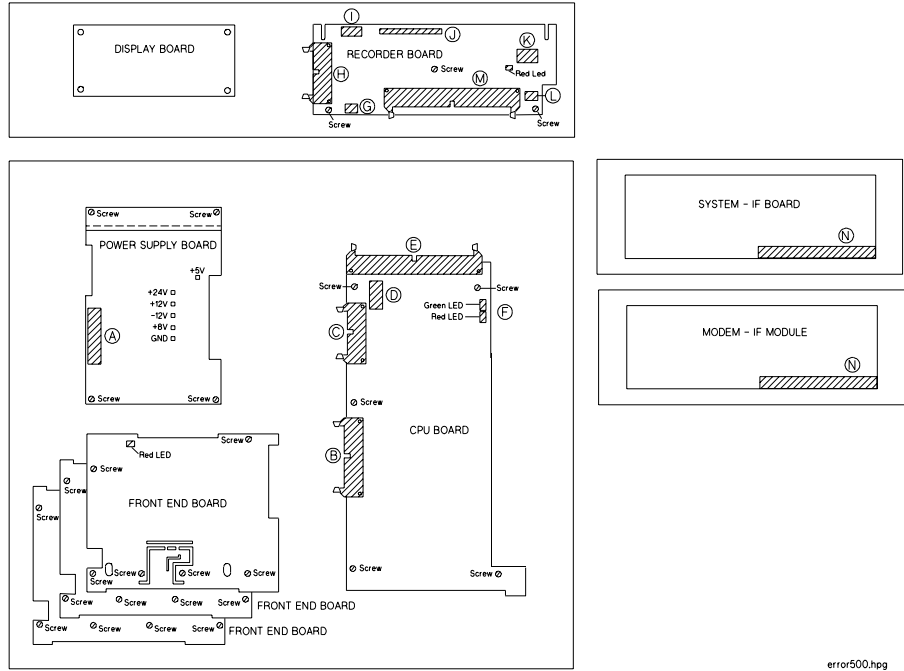

Figure 8-1 Troubleshooting: Error 500



error500.hpg

Figure 8-2 Connectors and LEDs

Error 501, 511, 512, 516, 517: Front End Board

Warning

The following task requires that the power be on while the cover is removed. Proceed only with extreme caution. Failure to do so can result in serious injury.

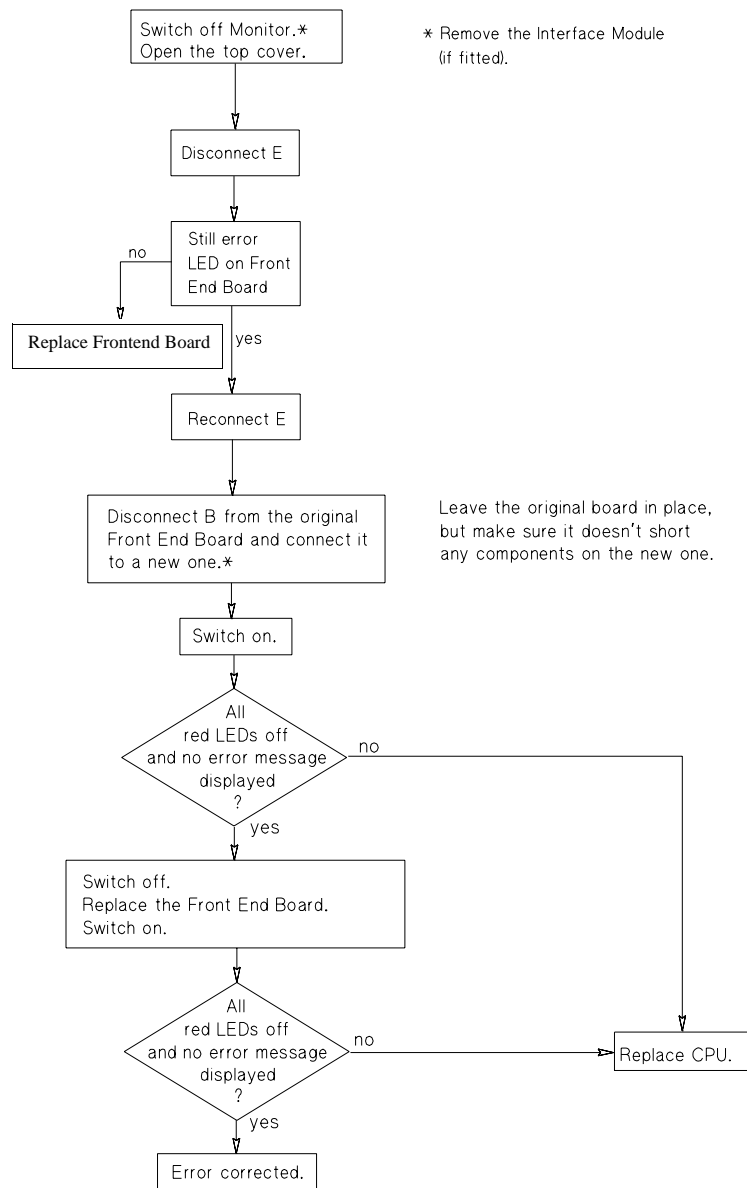
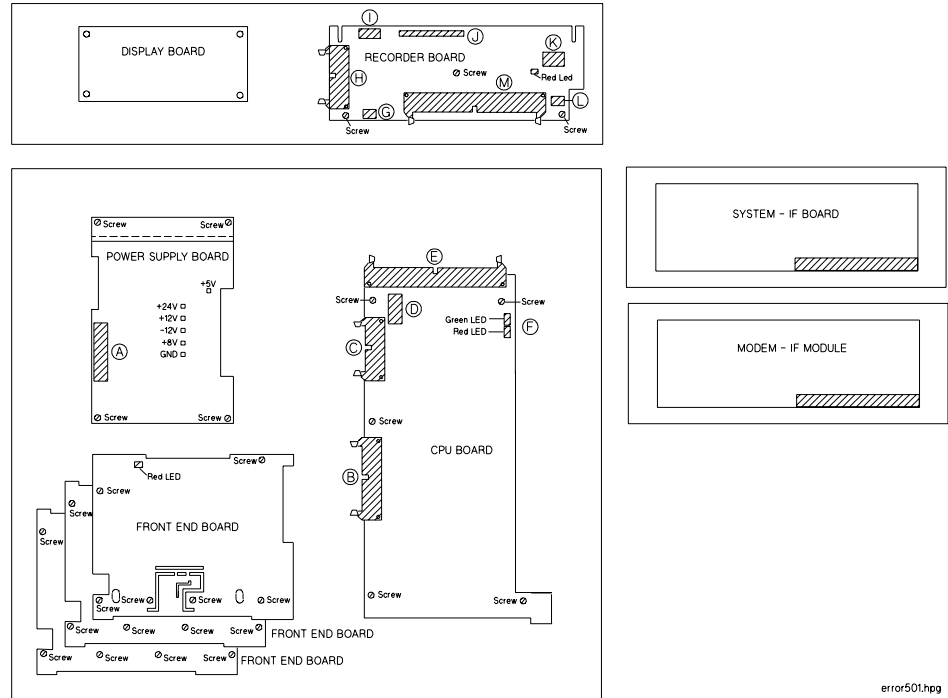

Figure 8-3 Troubleshooting: Error 501, 511, 512, 516 and 517



error501.hpg

Figure 8-4 Connectors and LEDs

Error 502: Power Supply

Warning

The following task requires that the power be on while the cover is removed. Proceed only with extreme caution. Failure to do so can result in serious injury.

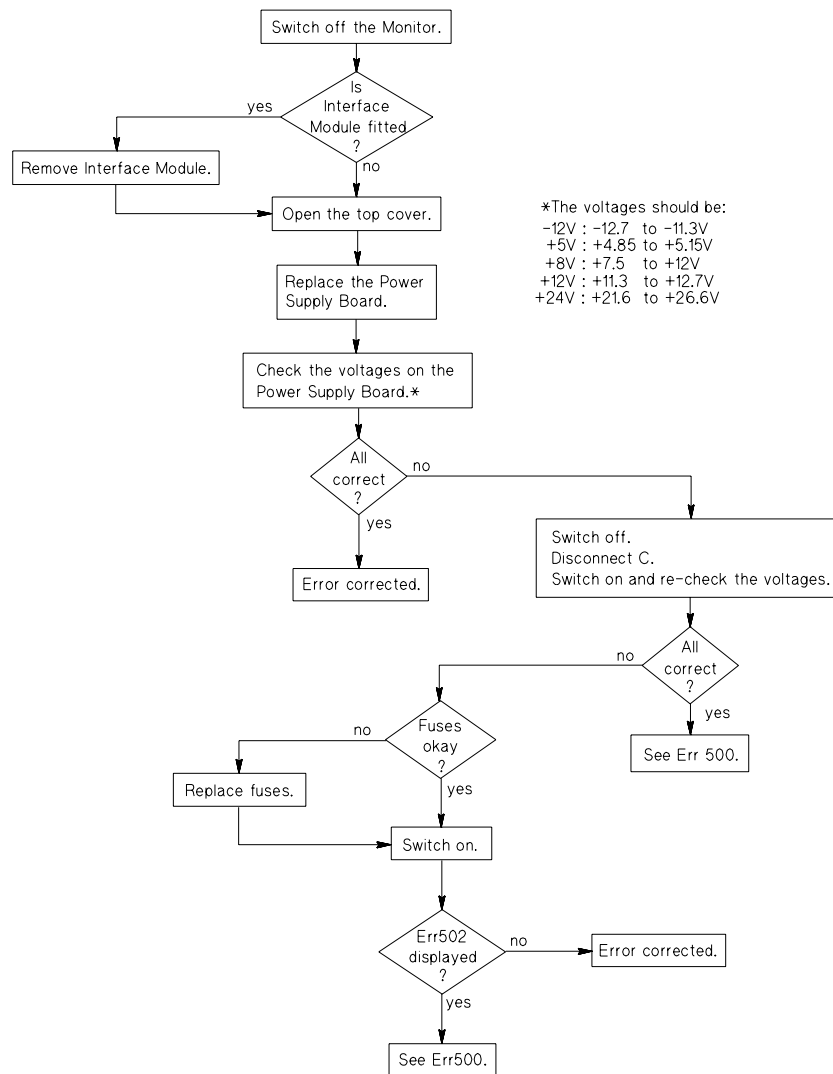

Figure 8-5 Troubleshooting: Error 502

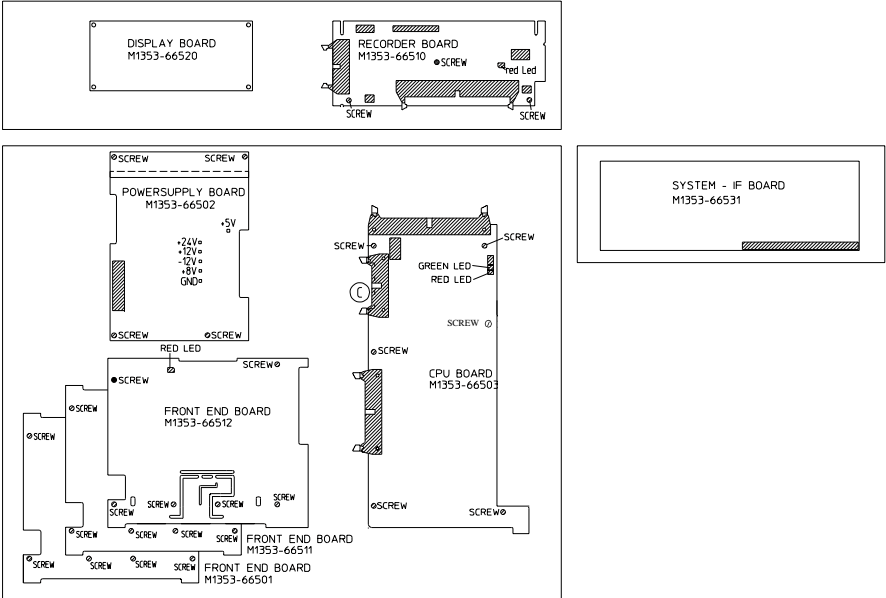

Figure 8-6 Connectors and Fuses

Error 503 and 513: CPU Board

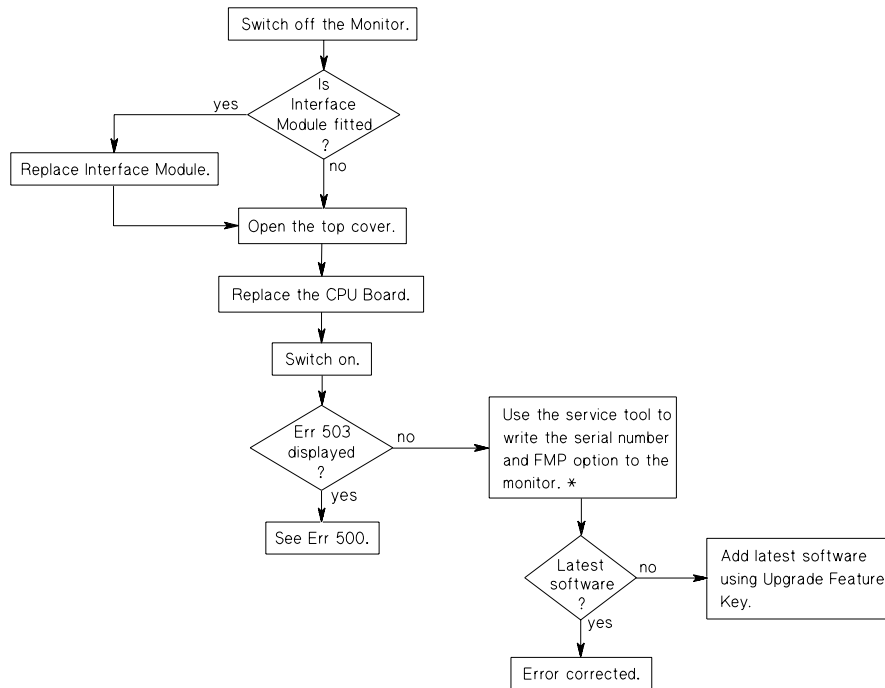

Figure 8-7 Troubleshooting: Error 503 and 513

Warning

The serial number and feature setting can only be written once.

Error 510: Recorder Board

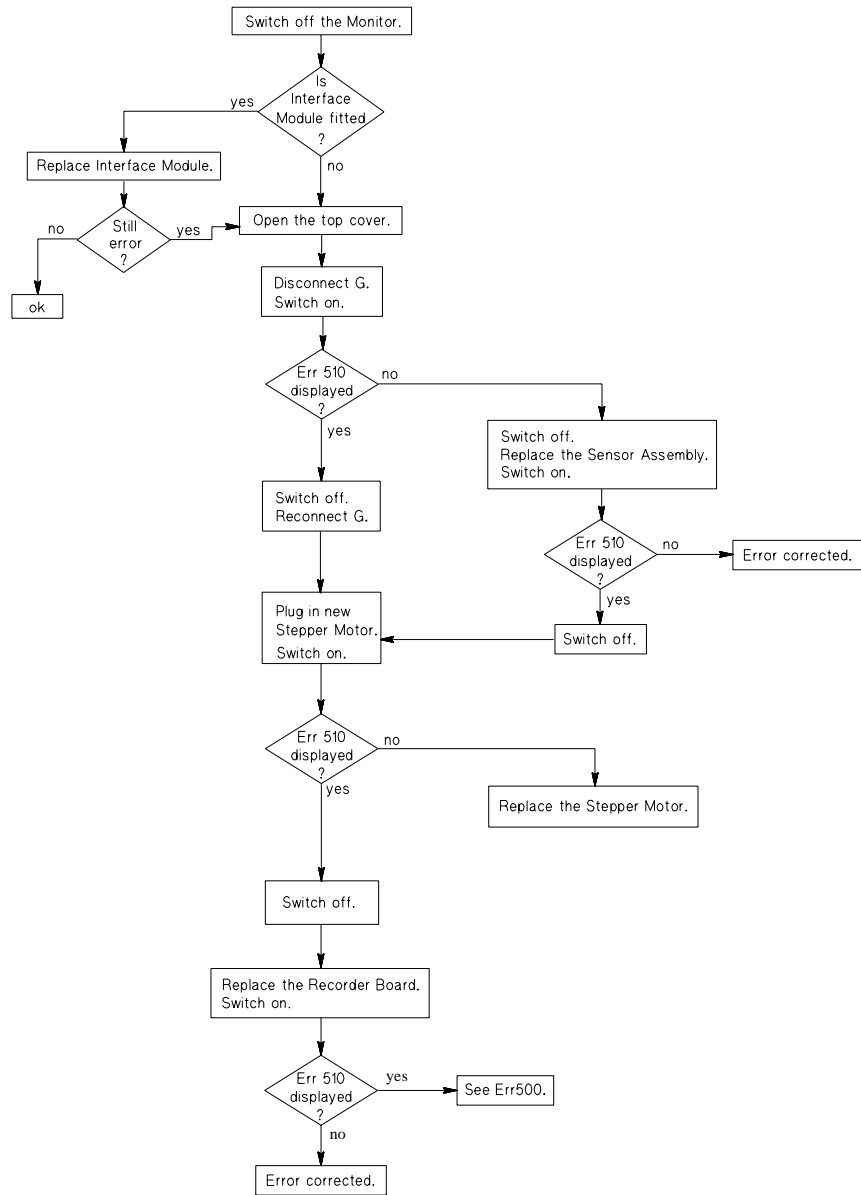

Figure 8-8 Troubleshooting: Error 510

See Figure 8-1 for position of connector G.

Error 531: Combined Interface Board

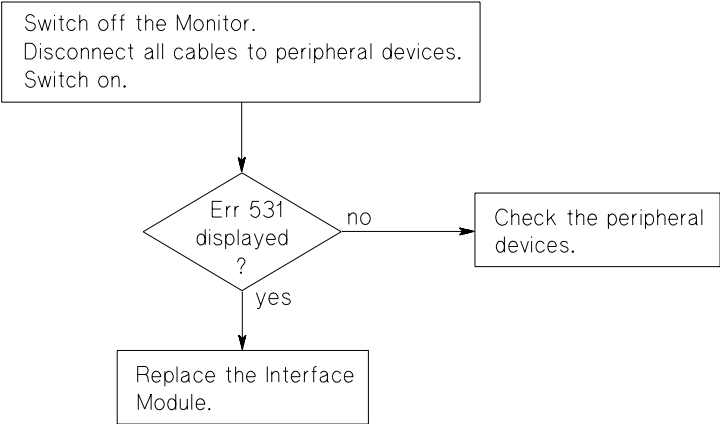
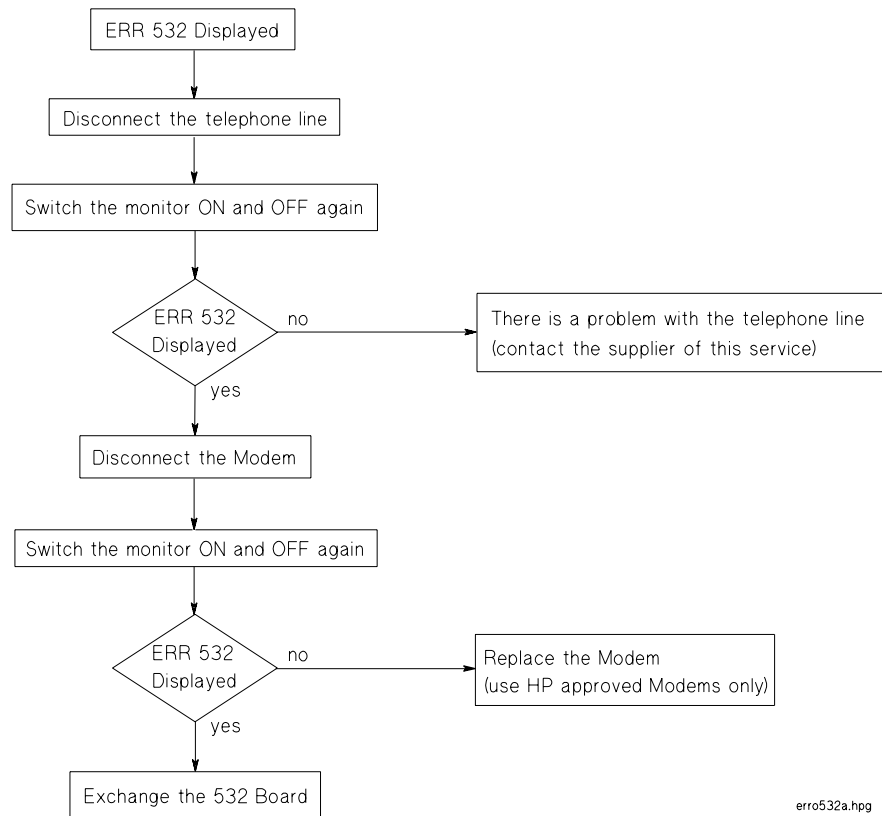
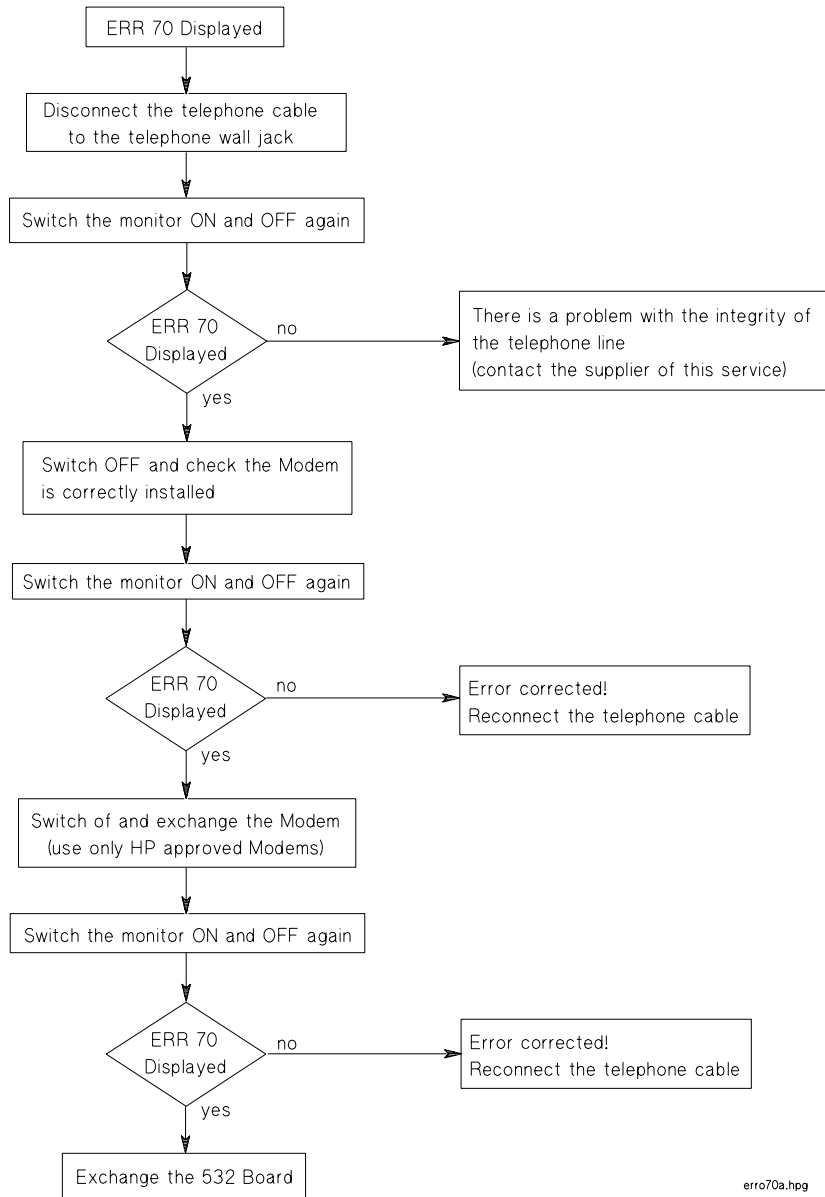

Figure 8-9 Troubleshooting: Error 531

Error 532: Modem Interface Board**Figure 8-10 Troubleshooting: Error 532**

Error 70: Modem Not Responding



erro70a.hpg

Figure 8-11 Troubleshooting: Error 70

Error 77: Modem Transmission Failure

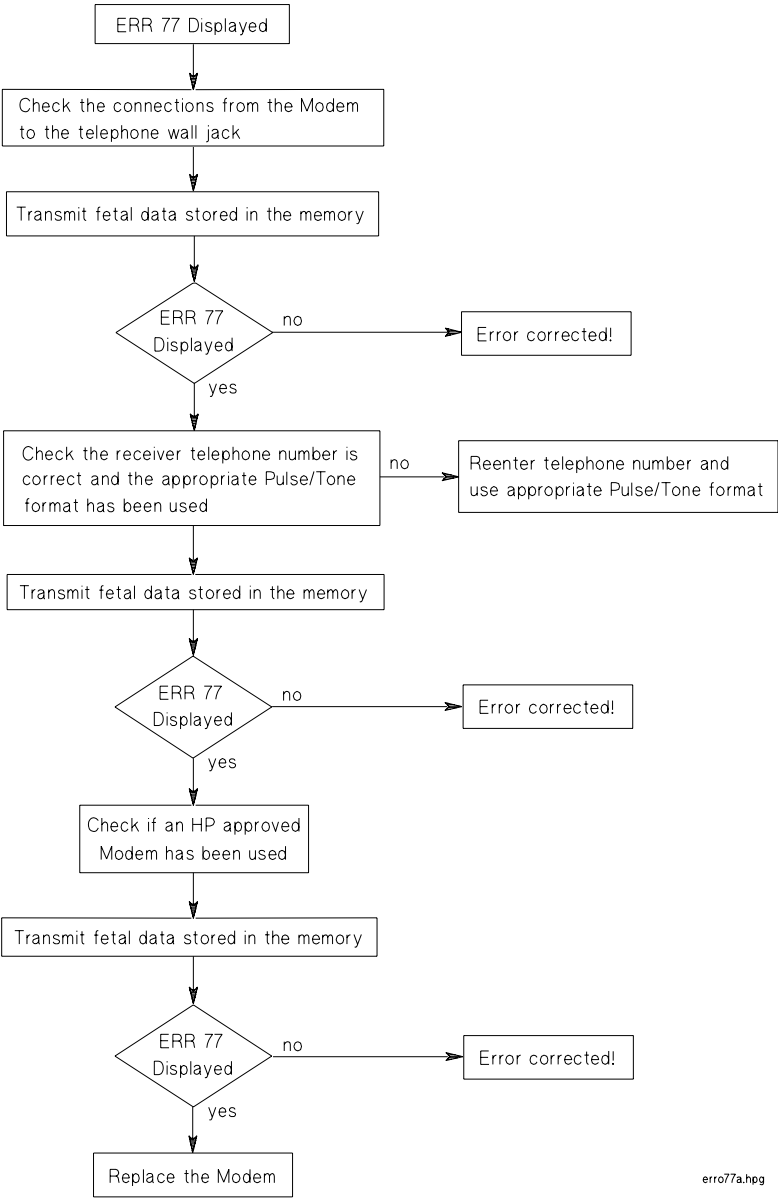

erro77a.hpg

Figure 8-12 Troubleshooting: Error 77

Error 601: Paper Feed

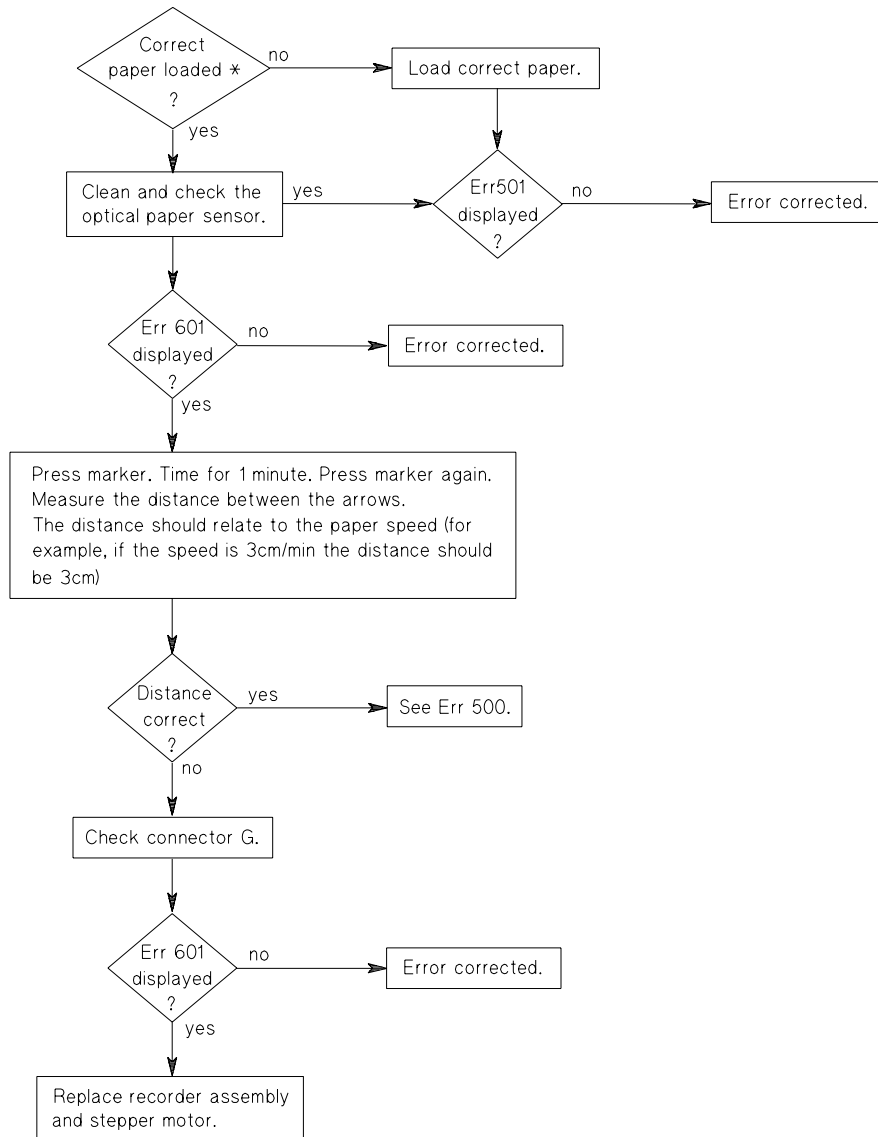

Figure 8-13 Troubleshooting: Error 601

See Figure 8-1 for position of connector G.

Caution

The use of recorder paper that is not approved by Philips can damage the monitor. This type of damage will not be covered by warranty.

Error 610: No Loudspeaker

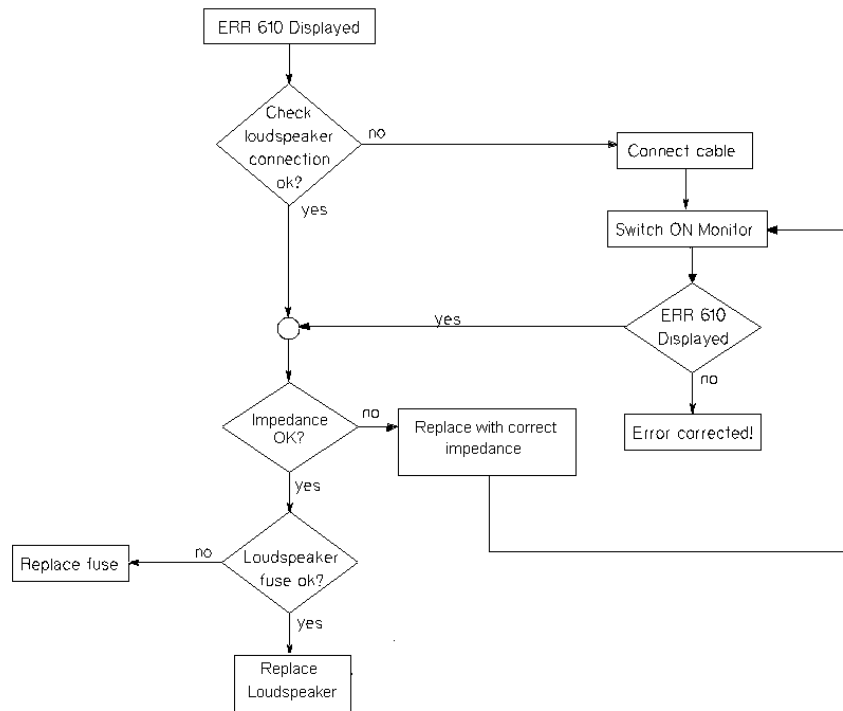

Figure 8-14 Troubleshooting: Error 610

Error 611: Loudspeaker

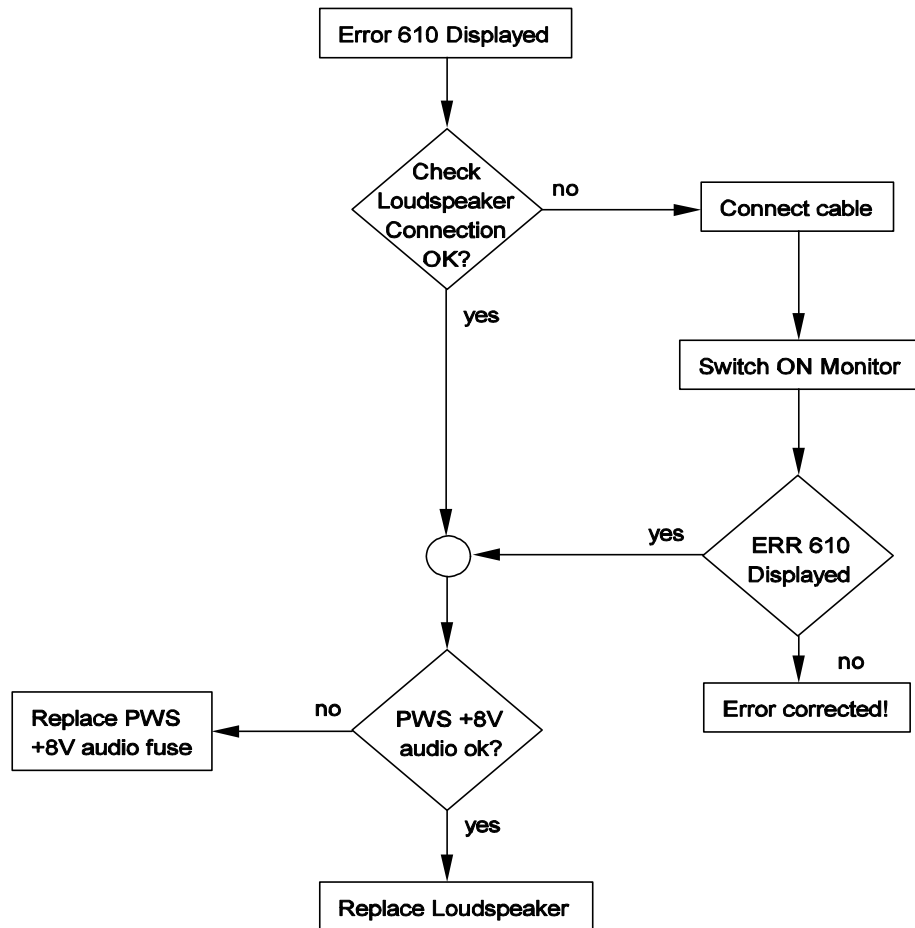

Figure 8-15 Troubleshooting: Error 611

Ultrasound Parameter Test

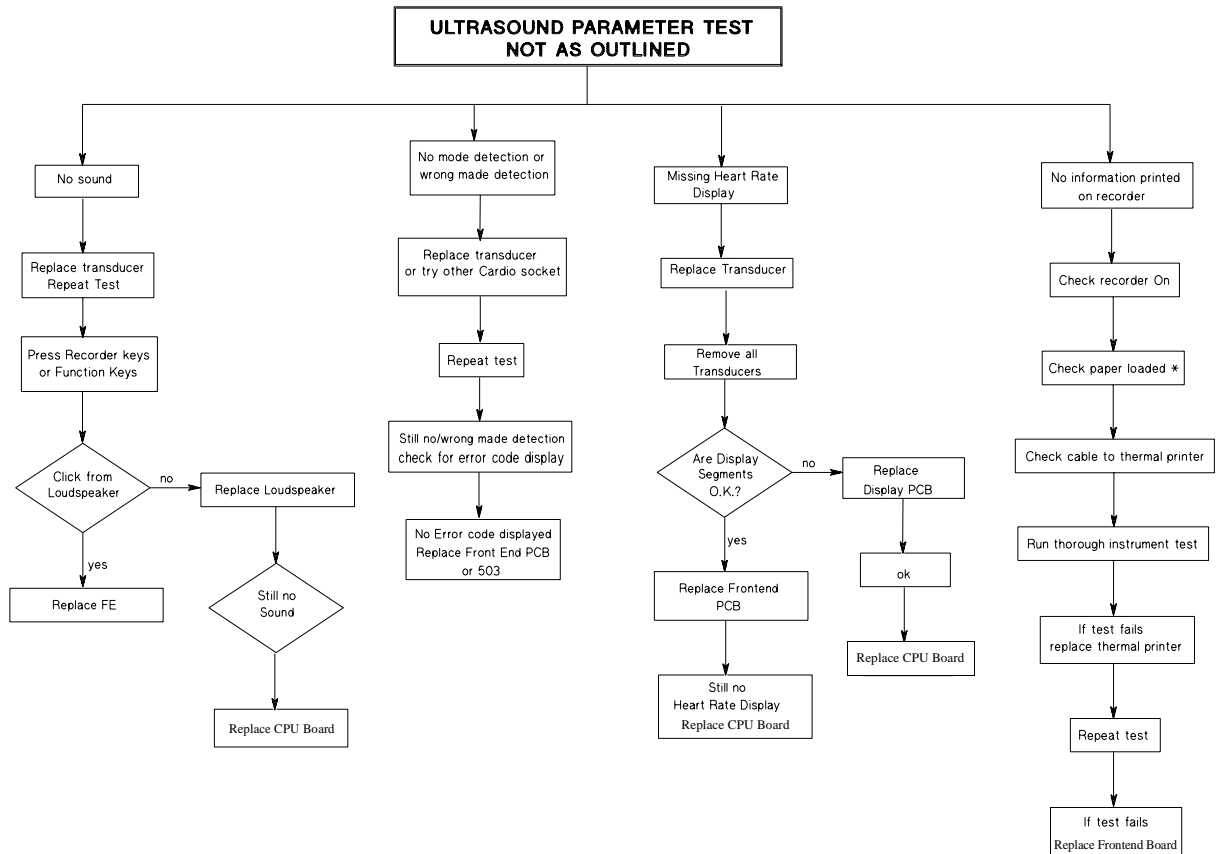

Figure 8-16 Troubleshooting: Ultrasound Parameter Test

DECG Parameter Test

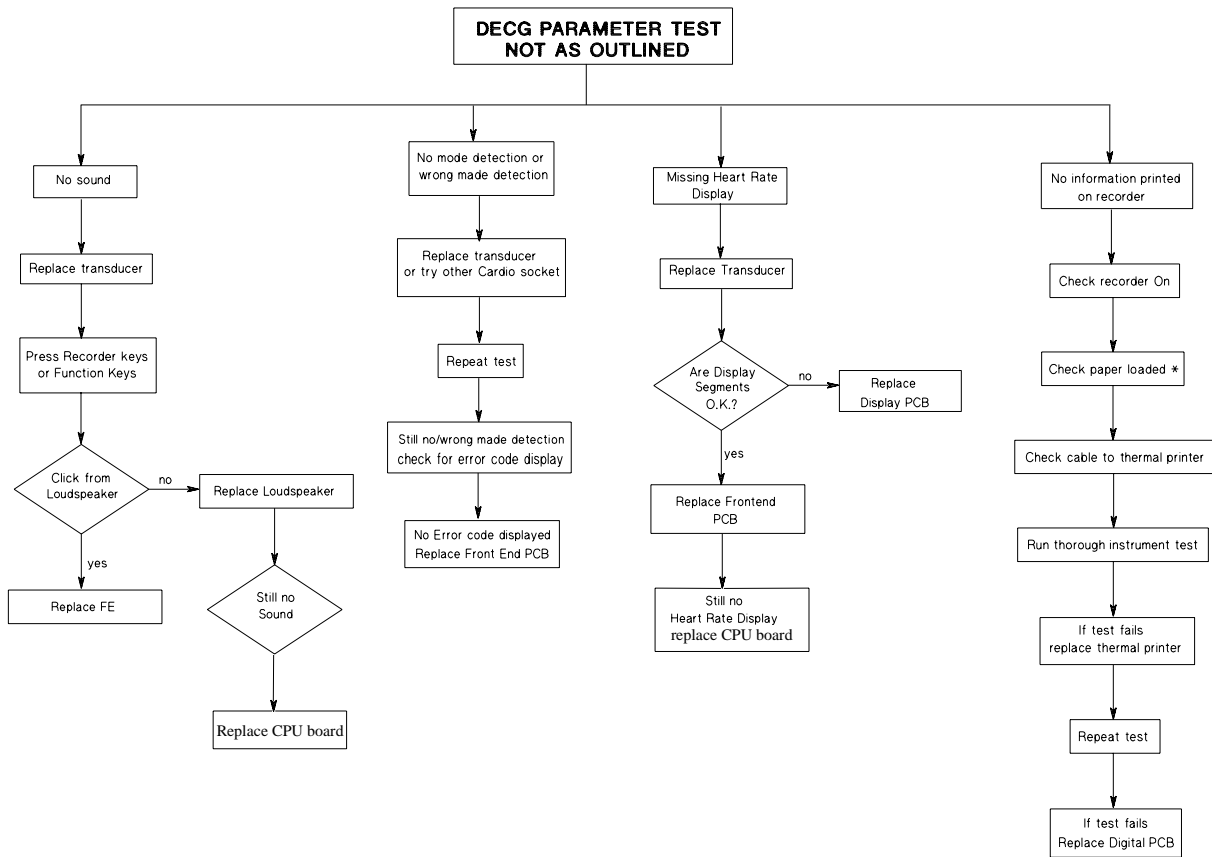

Figure 8-17 Troubleshooting: Direct ECG Parameter Test

MECG Parameter Test

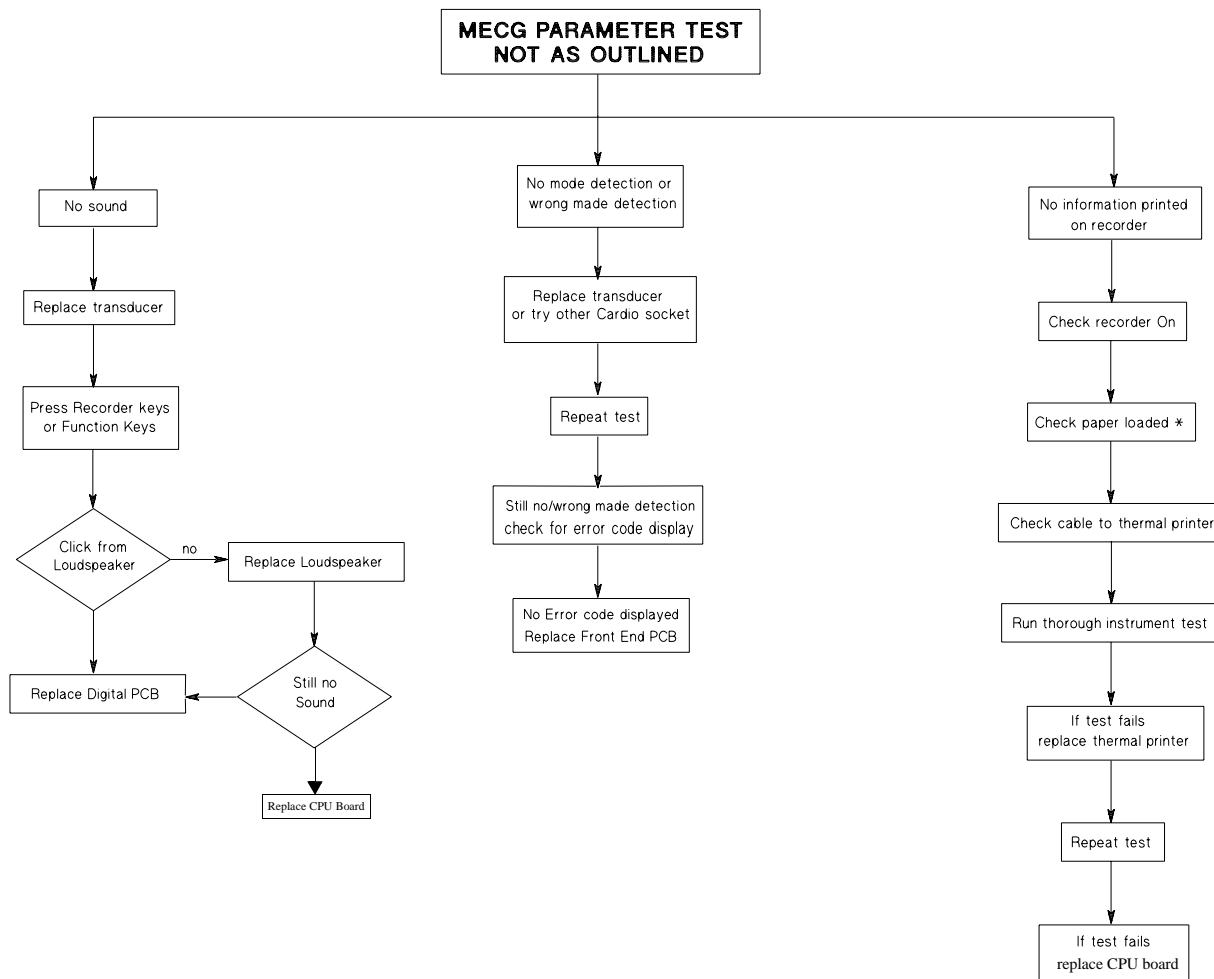

Figure 8-18 Troubleshooting: Maternal ECG Parameter Test

Toco Parameter Test

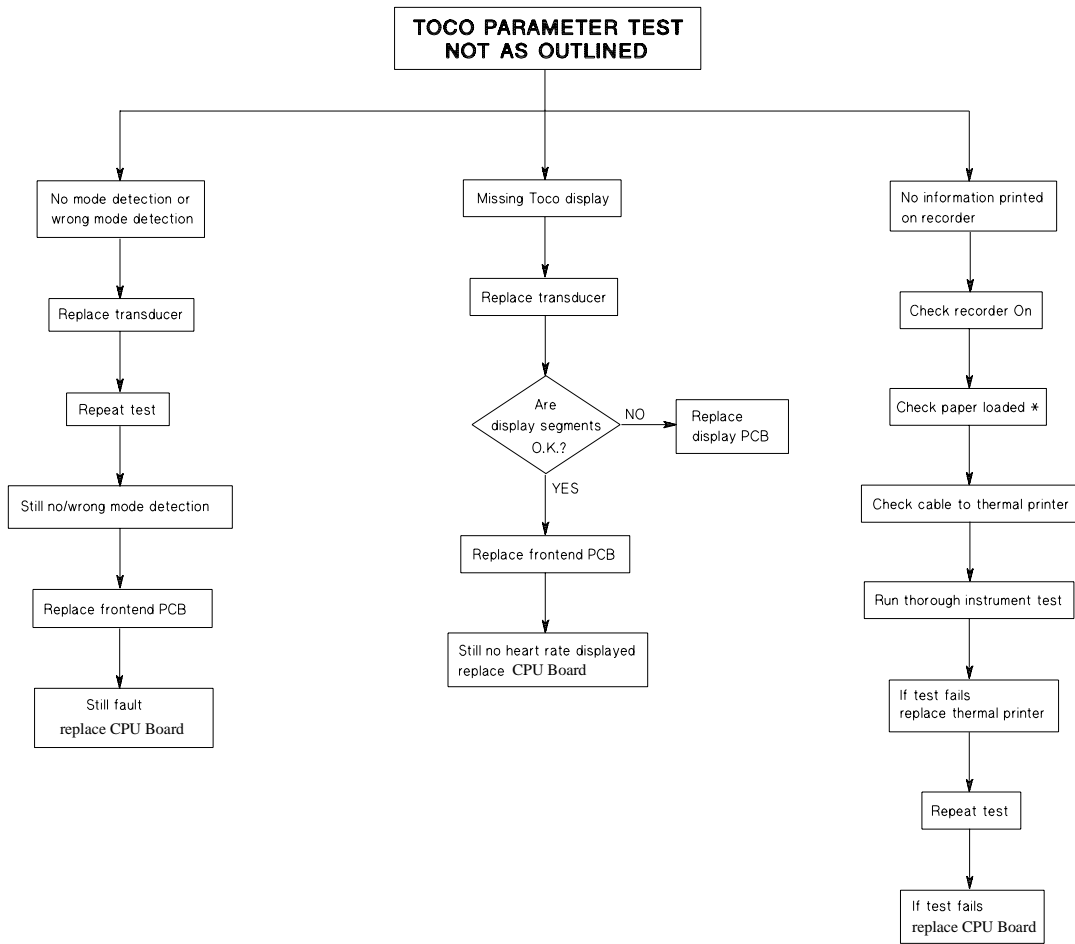

Figure 8-19 Troubleshooting: Toco Parameter Test

Maternal NIBP with the Dinamap 1846/8100 Monitor

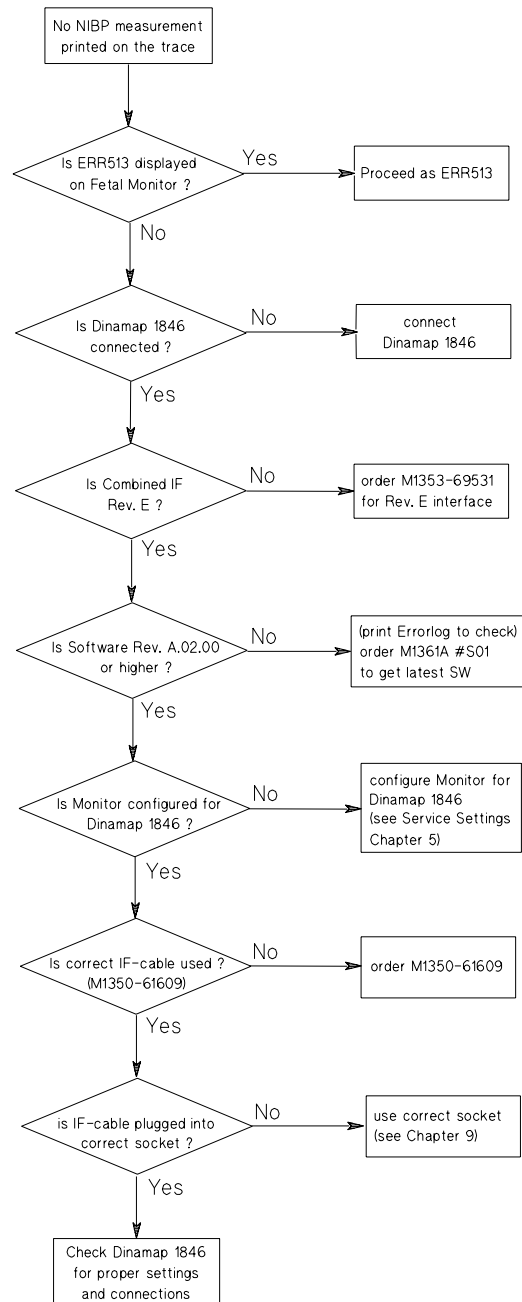

Figure 8-20 Troubleshooting: Maternal NIBP with the Dinamap™ 1846/8100 Monitor

Maternal NIBP with the COLIN Model BP-8800 Monitor

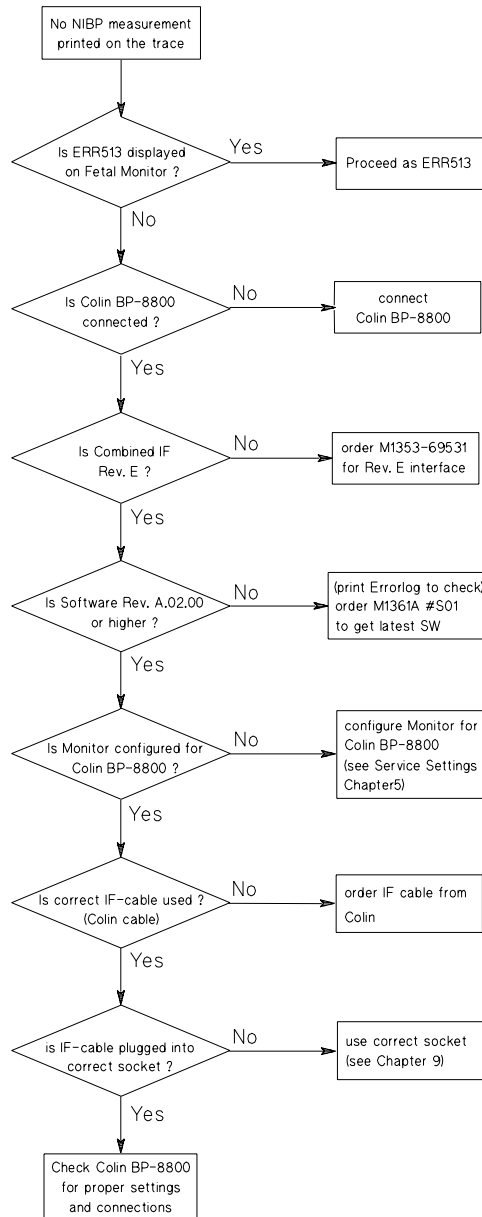

Figure 8-21 Troubleshooting: Maternal NIBP with the COLIN Model BP-8800 Monitor

Fetal Pulse Oximetry with Nellcor N-400 or Compatible Monitor

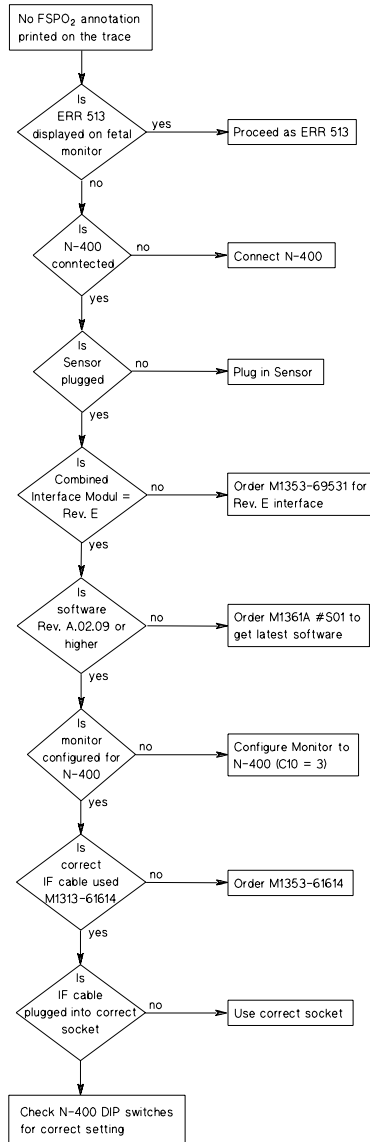

Figure 8-22 Troubleshooting: Fetal Oxygen Saturation with Nellcor N-400 or Compatible Monitor

Paper Sensing Test

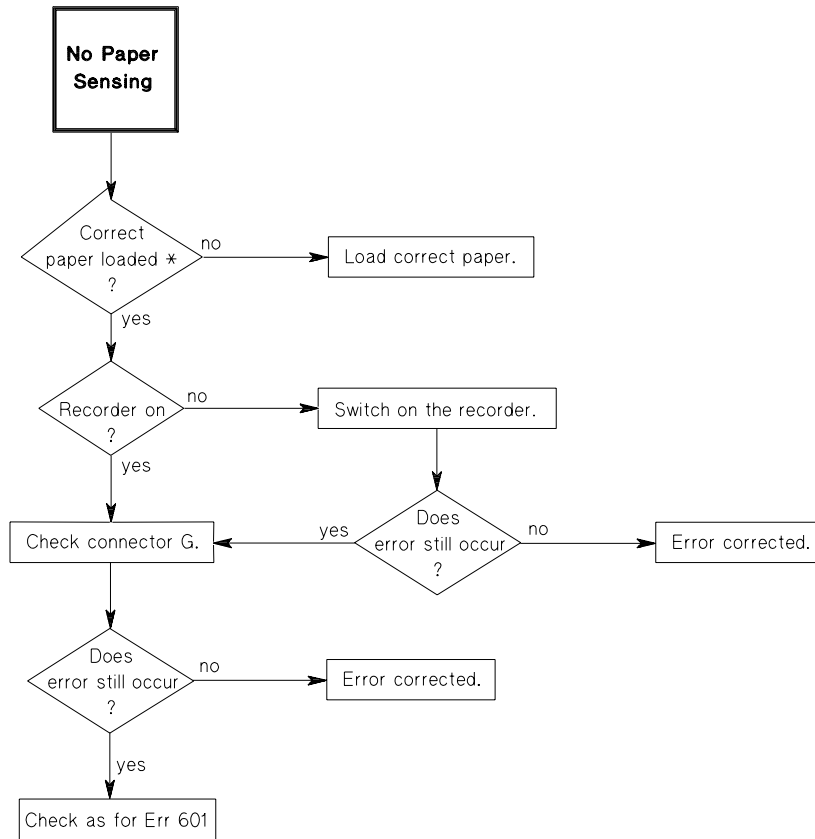

Figure 8-23 Troubleshooting: Recorder Paper Sensing

Caution

The use of recorder paper that is not approved by Philips can damage the Monitor. This type of damage will not be covered by warranty.

Preventive Maintenance, Care and Cleaning

Introduction

This chapter contains maintenance and safety information for the Series 50 A and Series 50 IP fetal monitors and accessories.

All checks that require the instrument to be opened must be made by qualified service personnel. Contact your local Philips representative if you wish safety and maintenance checks to be carried out by Philips personnel.

To ensure proper functioning of your monitor you must adhere to the standards described in this guide for:

- Cleaning
- Regular maintenance
- Accessory testing (transducer checks and patient module checks, page 97)
- Performance assurance checks (self test: see page 65, parameter test: see page 68, quick test: see page 66)
- Safety tests (safety test blocks: see page 100, instrument safety test: see page 105, system safety test: see page 105)
- Service tests (cyclic test: page 35, permanent test: see page 70)

Warning

Failure on the part of the responsible individual hospital or institution using this equipment to implement a satisfactory maintenance schedule may cause undue equipment failure and possible health hazards.

Cleaning the Monitor

For detailed instructions on how to clean the Series 50 A and Series 50 IP-2 fetal monitors and the monitoring accessories, see the User's Guide for your monitor.

For instructions on cleaning IUP transducer 1290C, see the instructions which are supplied with the transducer.

Regular Maintenance

This section details the periodic maintenance recommended for the fetal monitors and accessories. The tasks to be carried out are listed in Table 9-1

Table 9-1 Preventive Maintenance

Tasks and Tests
Replace the batteries (see page 137)
Carry out a mechanical inspection of the monitor
Check transducers, patient modules, cables, connectors and other accessories for cracks and defects
Carry out the Quick Test as described on page 66
Carry out the Parameter Test as described on page 68

Mechanical Inspection

To carry out a mechanical inspection of the monitor:

- Make sure all exposed screws are tight.
- Make sure that the combined interface module, if fitted, is firmly in place.
- Check the external cables and housings for splits, cracks or signs of twisting. Replace any cables that show serious damage.

Recorder Maintenance

The recorder platen, thermal print head and paper sensing mechanism must be cleaned at least once per year, or when needed (when traces become faint).

Clean the assemblies as follows:

- Clean the recorder platen with a lint-free cloth using a soap/water solution.
- Wipe the thermal array using a cotton swab moistened with 70% Isopropyl alcohol based solution.
- Check the paper sensing mechanism is dust free.
- Batteries: Replace the batteries with two alkaline 1.5 Volt size N batteries (recommended type: MN9100). For instructions on replacing batteries refer to page 137.

Accessory Testing

Testing Toco Transducers

Visual check Ensure that there are no cracks in the transducer dome, cable or connector plug.

- Electrical check**
1. Switch on the monitor and the recorder.
 2. Check configuration setting C11 (External TOCO gain) is set to 100% (C11 = 0): See “Configuring the Monitor” on page 32.
 3. Connect the transducer to the Toco socket. When you connect the transducer:
 - The Toco display shows 20.
 - **TOCO ext**, time, date and paper speed are printed on the paper.
 4. Lay the transducer face up on a flat surface for a few seconds.
 5. Press the Toco Baseline key to re-adjust the Toco display to 20.
 6. Turn the transducer over so that the button is face down on the flat surface. Hold the cable at a point 25 cm from the transducer and ensure that the transducer touches the flat surface only with the button and that the transducer is parallel to the flat surface.
- The Toco display should read between 40 to 50 units.

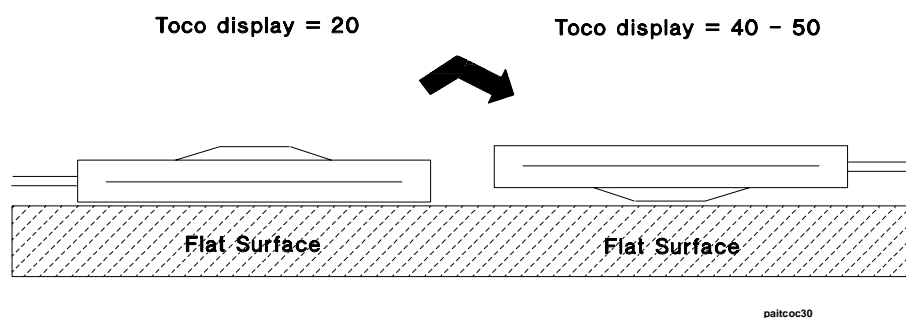

Figure 9-1 Testing a Toco Transducer

If the test fails, repeat using another transducer. If it still fails, refer to Chapter 8, “Troubleshooting Flowcharts.” After the test, you must zero the system by pressing the Toco Baseline Key.

Note— The external Toco recorder can be between 0 and 127 units.

Testing Ultrasound Transducers

Visual check Ensure that there are no cracks in the transducer dome, cable or connector plug.

- Electrical check**
1. Switch on the monitor and the recorder.
 2. Connect the transducer to the US socket. When you connect the transducer:
 - The --- display goes out.
 - **US**, time, date and paper speed are printed on the paper.
 - The Signal Quality Indicator is red.
 3. Turn the loudspeaker volume up to an audible level.
 4. Holding the transducer in one hand, move your other hand repeatedly towards and then away from the surface.

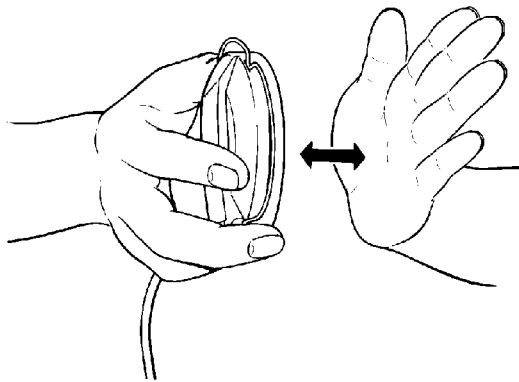

Figure 9-2 Testing an Ultrasound Transducer

Check that a noise is heard from the loudspeaker.

5. The transducer contains seven piezo-electric crystals.

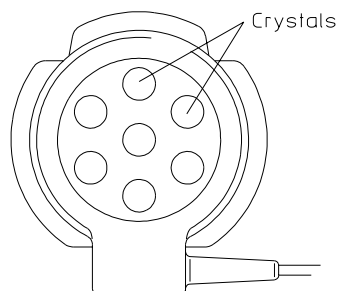
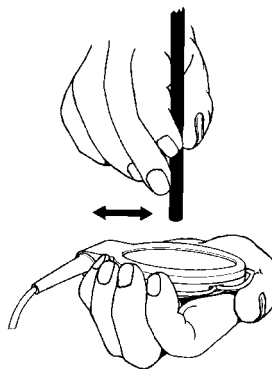

Figure 9-3 Position of Crystals in an Ultrasound Transducer

6. Holding the transducer in one hand, move a flat-bottomed pencil or similar object repeatedly towards and then away from each crystal. The distance between the pen and the transducer surface should be about 2 to 3 cm.



psm18c

Figure 9-4 Testing the Crystals

7. Check that a noise is heard from the loudspeaker for each crystal. If the test fails, repeat using another transducer. If it still fails, refer to Chapter 8, “Troubleshooting Flowcharts.”

Testing Patient Modules (M1364A)

Visual Check Ensure there are no cracks in the patient module and that the cable is not cracked or broken, and there are no cracks on the connector plug.

Electrical Check Connect the patient module to the ECG socket.

1. Ensure that the display shows **nop** without DECG adapter cable M1362A or M1362B.¹

IUP

Visual check Ensure that there are no cracks in the transducer dome, cable or connector plug.

- Electrical check**
1. Switch on the monitor and the recorder.
 2. Connect the transducer to the Toco socket. When you connect the transducer:

1. M1364A: in the presence of strong electrical fields (50-60Hz), **nop** may disappear even without additional cabling.

- The Toco display shows 0.
 - **TOCO int**, time, date and paper speed are printed on the paper.
3. Gently apply pressure to the syringe plunger. Check that the value on the display and paper shows this change in pressure.

If the test fails, repeat using another transducer. If it still fails, refer to Chapter 8, “Troubleshooting Flowcharts.”

Note— The Intrauterine Pressure Values can be between -99 and 127 units.

Safety Testing

This section defines the test and inspection procedures applicable to the Series 50 A and Series 50 IP fetal monitors. Use the tables in the following section to determine what test and inspection results must be reported after an installation or repair has been carried out.

- **Test Blocks** in Table 9-2 tells you when to carry out the safety tests
- **Test and Inspection Matrix** in Table 9-3 tells you how to carry out the safety tests.

Warning

Apply the safety test limits set by the local standards and statutes applicable to the country of installation, such as IEC 60601-1, UL2601-1, CAN/CSA-C22.2 No. 601.1-M90.

The safety tests defined in this chapter are derived from local and international standards but may not be equivalent. They are NOT a substitute for local safety testing.

Caution

Successful completion of the patient safety tests does not ensure the correct and accurate functioning of the equipment.

Safety Test Procedures

The test procedures outlined in this section are to be used only for verifying the safe installation or service of the product. “Safety checks at installation refer to safety aspects directly related to the installation and setup activities and not to intrinsic safety features that have already been checked during final acceptance testing at the factory.”
[FDA 97-4179 Medical Quality Systems Manual: A Small Entity Compliance Guide (QSR manual). First Edition December 1996. Chapter 14: Storage, Distribution and Installation. This document may be viewed at <http://www.fda.gov>].

When running safety tests on the peripheral components of the system, refer to the

documentation included with those products.

When performing safety tests, you must use a standard safety tester. You can use testers complying with IEC 60601-1 internationally. You may also use testers complying with any local standards and statutes applicable to the country of the installation. For safety test procedures see the operation instructions of the safety tester used.

If using the Metron safety tester use your local regulations to perform the test, for example

- in Europe: IEC60601-1/IEC60601-1-1
- in the US: UL2601-1

The Metron Report should print results as detailed in this chapter, along with other data.

Note— For information and ordering guides for Metron products contact:

Metron AS, Travbaneveien 1, N-7044 Trondheim, Norway

Tel (+47) 73 82 85 00; Fax (+47) 73 91 70 09;

E-mail: sales@metron.no/support@metron.no

www: <http://www.metron-biomed.com>

When to Perform Safety Tests

Table 9-2M1351A and M1353A: When to perform safety test blocks

Service Event	Test Block(s) Required
<p>Installation The product is <i>customer installed</i>. You will find installation instructions in this Installations and Service Guide.</p>	<p>Perform Visual, Power On and Performance test blocks (See Table 9-3).</p>
<p>Preventive Maintenance Preventive Maintenance is the responsibility of the customer For preventive maintenance refer to page 96.</p>	<p>Perform Visual test block (see Table 9-3).</p>
<p>Repair This Installation and Service Guide contains repair instructions for the 50 A and 50 IP monitors.</p>	<p>Perform Visual, Power On and Performance test blocks (see Table 9-3), when <i>power switch is replaced</i> perform S2-Safety test block (see page 104), when <i>transformer</i> is replaced perform S3-Safety test block (see Table 9-3). When <i>Frontend-Board is replaced</i> perform S3-Safety test block (see Table 9-3).</p>
<p>Upgrade This Installation and Service Guide contains upgrade instructions for the 50 A and 50 IP monitors.</p>	<p>Perform Visual, Power On, Performance and Safety test blocks (see Table 9-3).</p>
<p>All other Service Events</p>	<p>Perform Visual, Power On and Performance test blocks (see Table 9-3).</p>

Test and Inspection Matrix

Key to Table: P = Pass and F = Fail, X = test result value to be recorded.

Table 9-3 M1351A/ M1353A Fetal Monitor - Test and Inspection Matrix

Test Block Name	Test or "Inspection" to Perform	Expected Test Results	What to Record on Service Record (Philips Personnel only)
<u>Visual</u>	Inspect the unit, transducers and cables for any damage. Are they free of damage?	If Yes, Visual test is passed.	V:P or V:F
<u>Power On</u>	Power on the unit. Does the self-test complete successfully?	If Yes, Power On test is passed.	PO:P or PO:F
<u>Performance</u>	Perform the quick test and parameter test! Do these tests complete without errors?	If Yes, Performance Test is passed.	P:P or P:F
<u>Safety(2)</u>	Protective Earth. See -104 - Safety (2)	With mains cable: Maximum impedance = x (≤ 200 mOhms)	S2:P/x or S2:F/x
<u>Safety(3)</u>	Enclosure Leakage Current - Normal Condition. See -104 - Safety (4)	Maximum leakage current = x1 ($\leq 100\mu\text{A}$)	S2:P/x4 or S2:F/x4
	Enclosure Leakage Current - S.F.C Open Supply. See -104 - Safety (5)	Maximum leakage current = x2 ($\leq 500\mu\text{A}$) (Note: maximum leakage current in the US = $300\mu\text{A}$)	S2:P/x2 or S2:F/x2
	Enclosure Leakage Current - S.F.C Open Earth. See -104 - Safety (6)	Maximum leakage current = x3 ($\leq 500\mu\text{A}$) (Note: maximum leakage current in the US = $300\mu\text{A}$)	S2:P/x3 or S2:F/x3
<u>Safety S (3)</u>	M1353A only: ONLY TOCO-input tested, Metron Testconn. required. (Metron order # 19528 and Philips Adapter M1940A) Patient Leakage Current - S.F.C. Mains on Applied Part. See -104 - Safety (3)	Maximum Leakage current = x ($\leq 50\mu\text{A}$ @ 250V or $\leq 20\mu\text{A}$ @ 120V)	S3(S):P/x or S3(S):F/x

Safety Tests

S(2): Protective Earth Test

Test to perform:

The protective earth test measures impedance of Protective Earth (PE) terminal to all exposed metal parts of the Instrument Under Test (IUT) which are connected to the Protective Earth (PE) for safety reasons. Normally it includes the wiring in the mains cable (max. 200 mOhm).

A test current of 25 Amps is applied for 5 to 10 seconds. It is recommended to flex the main cable during the test to identify potential bad contact or damage to the earth wire.

Safety test according to IEC 60601-1 (Clause 18).

Report the highest value.

S(3): Patient Leakage Current Test - AC

Test to perform:

The patient leakage current test measures patient leakage current from the applied part to the earth caused by external main voltage on the applied part. Each polarity combination possible is to be tested. This test is applicable for ECG and SpO₂.

Safety Test according IEC 60601-1 (Clause 19.4b).

Report the highest value.

S(4): Enclosure Leakage Current Test - Normal Condition (NC)

Test to perform:

The enclosure leakage current: normal condition test is applicable to Class 1 and 2 equipment, type B, BF, and CF Applied Parts. The test measures leakage current of exposed metal parts of the Instrument Under Test; it also tests normal and reversed polarity.

For Type BF and CF Applied Parts the test measures AP/GND.

Safety Test according to IEC 60601-1 (Clause 19.4g).

Report the highest value.

S(5): Enclosure Leakage Current Test - Single Fault Condition (SFC) Open Supply

Test to perform:

The enclosure leakage current: single fault condition open supply is applicable to Class 1 and 2 equipment, type B, BF, and CF Applied Parts. The test measures leakage current of exposed metal parts of the Instrument Under Test with one supply lead interrupted; it also tests normal and reversed polarity.

For type BF and CF Applied Parts the test measures AP/GND.

Safety Test according IEC 60601-1 (Clause 19.4g).

Report the highest value.

S(6): Enclosure Leakage Current Test - Single Fault Condition Open Earth (Ground)

Test to perform:

The enclosure leakage current: single fault condition open earth (ground) test is applicable to Class 1 equipment, type B, BF and CF Applied Parts. The test measures leakage current of exposed metal parts of the Instrument Under Test with Protective Earth open-circuit and normal; it also tests reversed polarity. For type BF and CF Applied Parts the test measures AP/GND.

Safety Test according IEC 60601-1 (Clause 19.4g).

Report the highest value.

Instrument Safety Test You must perform the instrument safety test every time you exchange, repair, upgrade or in any other way work on the **front end board**, the **power supply**, or the **power inlet**. If you intend to connect the monitor to an obstetrical information management system such as OB **TraceVue**, you **must** perform the instrument safety test with the monitor as a standalone unit, before reconnecting it to the system.

The instrument safety test is made up of four separate tests (see page 104):

- Protective Earth Test
- Enclosure Leakage Current - Normal Condition
- Enclosure Leakage Current - Single Fault Condition
- Patient Leakage Current - Single Fault Condition

System Safety Test Whenever you connect a monitor to an obstetrical system such as OB **TraceVue** you must perform the System Test. The System Test consists of the Enclosure Leakage Current tests (normal and single fault condition) as described on page 104. You must run this test when connecting either a new or repaired monitor.

Fitting the Combined Interface Module

To fit the Combined Interface Module:

1. Remove the screw which holds the interface socket cover in place on the base of the monitor and then remove the interface socket cover.
2. Connect the Combined Interface Module.
3. Screw the module in place.

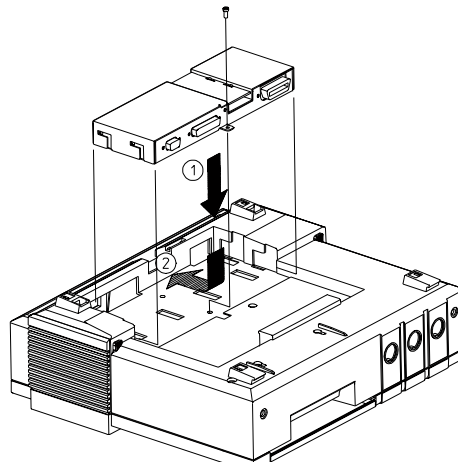

Figure 10-1 Fitting the Combined Interface Module

With the module fitted, you can connect the following peripherals to the monitor:

- One of the following to the RS232 serial interface:
 - HBCR8200 Barcode Reader.
 - Dinamap™ 1846/8100 maternal NIBP Monitor.
 - COLIN Press-Mate™/Nippon Colin Model BP-8800 maternal NIBP Monitor.
 - Nellcor OxiFirst™ Fetal Oxygen Saturation monitor.
- M2720A Avalon CTS Cordless Fetal Transducer System or M1310A Fetal Telemetry to the telemetry socket.
- M1383A/B/C OB **TraceVue** to the system interface.

Connecting Peripheral Devices

If the monitor has the Combined Interface Module, you can connect:

- OB TraceVue
- Telemetry System
- and *one* of the following:
 - Barcode Reader
 - Maternal NIBP Monitor
 - FSpO₂ Monitor

To connect the peripheral devices:

1. Lift out the connector cover (A).
2. Connect the peripheral devices to the sockets on the Interface Module.
3. Tighten the screws on the connectors.
4. Feed the cables through the hollow in the center of the Interface Module (B) and then push the cable clamp into place.

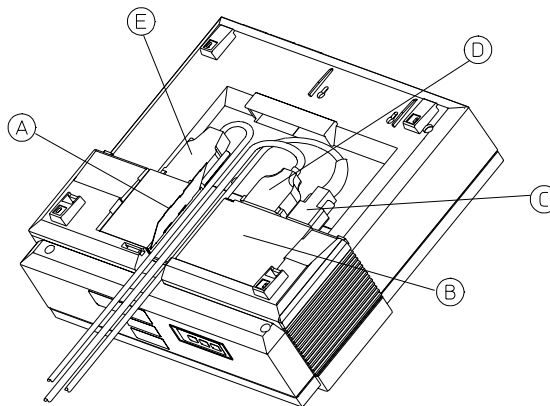

Figure 10-2 Connecting Peripheral Devices

Key to diagram:

- | | |
|---|---|
| C | RS232 Serial Interface (Barcode or NIBP or FSpO ₂ Monitor) |
| D | Telemetry Interface |
| E | System Interface (M1353-66531E is required for OB TraceVue) |

Note— To connect a fetal monitor to the obstetrical surveillance system OB TraceVue M1383A/B/C, you will need the Combined Interface Module M1353-66531 rev. E (part number M1353-66531E) and fetal monitor firmware rev. A.02.02 or later. You will also need the Interface Cable M1380-61613 (or the equivalent OB TraceVue cable, Option #K13).

RS232 Serial Interface

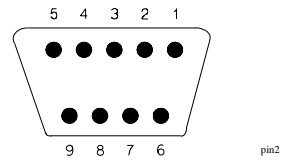

Figure 10-3 RS232 Interface Pin Connections

The following table lists the signals at each pin.

Table 10-1 RS232 Interface Pin Connections

Pin	Signal	Details
1	CD	Carrier detect (connected to pin 4)
2	RxD Input	Receive data from external devices
3	TxD Output	Transmit data to external devices
4	DTR	Data terminal ready (connected to pin 1)
5	GND	Ground
6		Not connected
7	B_Gnd	Barcode Smartwand Ground
8		Not connected
9	V _{cc}	+5V, 10mA (idle) to 25mA (configure)

Barcode Reader After installing the Barcode Reader, you must check that it is connected correctly and that the monitor is configured to read the barcodes. See the User’s Guide for your monitor for details of how to use the Reader.

1. Using the Reader, read **Test Barcode 1** and then **Test Barcode 2** from the barcode sheet.
2. Check that **TEST OK5** is printed on the paper.

If it is not, switch the monitor off and on and repeat the test. If it is still not printed, connect a new reader.

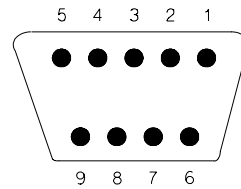

Figure 10-4 Barcode Reader Pin Connections

The following table lists the signals at each pin.

Table 10-2 Barcode Reader Pin Connections

Pin	Signal	Details
1		Not connected
2	RxD Input	Receive data from Smart Wand
3	TxD Output	Transmit data to Smart Wand
4		Not connected
5		Not connected
6		Not connected
7	Gnd	Ground
8		Not connected
9	V _{cc}	+5V, 10mA (idle) to 25mA (configure)

NIBP Monitor

One of the following devices can be connected to an M1351A or M1353A to record maternal NIBP:

- Dinamap™1846/8100 NIBP Monitor. This requires a Critikon model 8801 adapter
- COLIN Press-Mate/Nippon Colin Listmini Model BP-8800.

Before connecting a NIBP monitor, ensure that the correct configuration options on the M1351A and M1353A have been selected. See Table 4-2 on page 27 for the options available. Interface to an NIBP Monitor is available only on the Combined Interface Module, Option J13, with the label M1353-66531, E (software revision number A.02.xx or higher - the software revision number is written on the error log).

**Connecting
an NIBP Monitor to
the M1351A or
M1353A**

To connect a Dinamap™ 1846/8100 NIBP Monitor to the M1351A or M1353A:

1. Use the interface cable M1350-61609.
2. Connect the 9-pin end of the cable to the fetal monitor.
3. Connect the 25-pin end of the cable to the external device.
4. Secure the interface cable by the screws at the cable connectors.

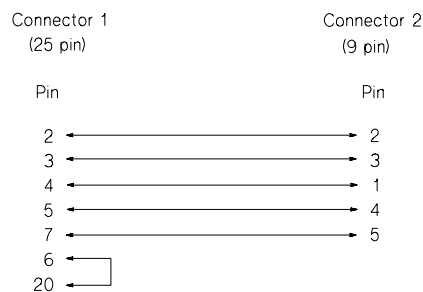

Figure 10-5 Interface Cable M1350-61609

Caution

Before connecting an NIBP Monitor, use the Grounding Cable (part number 8120-2961 for USA or 8120-4808 for Europe) to connect the equipotential grounding point on the fetal monitor to earth potential. The power cord of the NIBP Monitor must be plugged into a wall-mounted power outlet - not into an extension block.

To connect a COLIN Model BP-8800 Monitor to the M1351A or M1353A:

1. Use the interface cable supplied by the COLIN Corporation with the NIBP Monitor.
2. Connect the 9-pin end of the cable to the fetal monitor.
3. Connect the 15-pin end of the cable to the COLIN.
4. Secure the interface cable by the screws at the cable connectors.

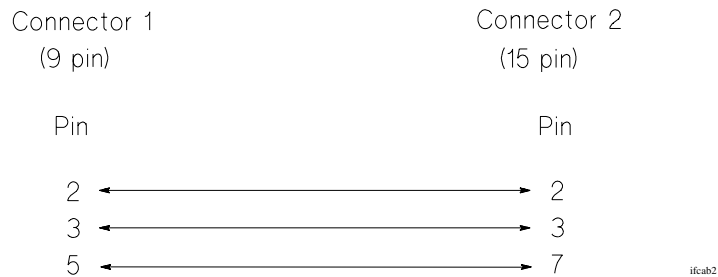

Figure 10-6 COLIN Interface Cable

Baudrates The baudrates for each external device must be set as follows:

COLIN BP-8800	Baudrate:	4800			
	Startbit:	1	Parity:	Even	
	Databits:	8			
	Stopbits:	1			
	Cable:	Supplied by the COLIN Corporation.			

Dinamap™ 1846/ 8100	Baudrate:	600			
	Startbit:	1	Parity:	None	
	Databits:	8			
	Stopbits:	1			
	Cable:	M1350-61609 or M1350-61608.			

Maternal Measurements on the FHR Trace

Each time an external device takes the maternal NIBP measurement it is printed on the trace. When you monitor NIBP, an MHR measurement is printed at the same time as the NIBP measurement.

If you set the NIBP Monitor to automatic mode, you must leave a minimum time interval between each measurement to print every value. This time interval depends upon the paper speed setting.

Table 10-3 NIBP Monitor and Minimum Time Interval

Paper Speed	Minimum Time Interval
1 cm/min	3 minutes.
2 cm/min	2 minutes.
3cm/min	1 minute.

FSpO₂ Monitor

If the fetal monitor has the Combined Interface Module J-14 fitted, you can interface to an FSpO₂ monitor (Nellcor N-400 or other compatible). You must have software revision number A.02.09 or higher.

To connect an FSpO₂ monitor to the M1351A or M1353A:

1. Use interface cable M1353-61614. This has identical 9-pin male connectors at each end.
2. Connect one end to the M1351A or M1353A and the other to the FSpO₂ monitor.
3. Secure the interface cable by the screws at the cable connectors.

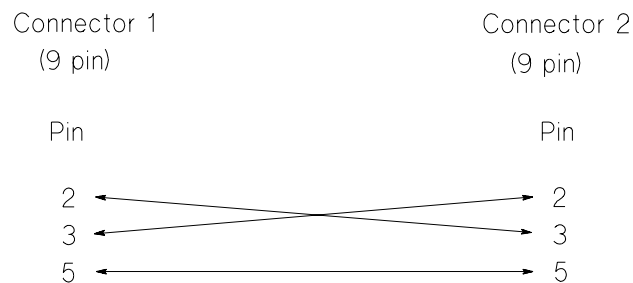
**Figure 10-7 FSpO₂ Interface Cable (M1353-61614)**

Baudrates The baudrates for the FSpO₂ monitor must be set as follows:

Baudrate:	2400	Parity:	None
Startbit:	1		
Databits:	8		
Stopbits:	1		
Cable:	M1353-61614		

DIP Switch Settings The DIP switches for the FSpO₂ monitor must be set as follows:

Table 10-4 FSpO₂ monitor DIP Switch Settings

DIP Switches and Settings									
1	2	3	4	5	6	7	8	9	10
*	*	▼	▲	*	▼	▼	▲	*	*

DIP switches 3 and 4 set the baud rate to 2400. 6, 7, and 8 set the output format to conversation mode. The positions of the other switches, shown with asterisks (*) above, do not matter and may be either up or down.

Troubleshooting FSpO₂ If the FSpO₂ monitor has two power switches (a mains switch at the rear of the unit and a standby switch at the front of the unit) you should take care to switch them off and on in the correct order. Failure to follow this prescribed sequence can cause the unit to appear to malfunction by displaying data erratically, or not at all.

Switching off

1. Turn front switch (on/standby mode) to standby.
2. Turn rear switch (mains power switch) to off.

Switching on

1. Turn rear switch (mains power) to on.
2. Turn front switch (on/standby mode) to on.

If the unit behaves erratically, switch it off, exactly as detailed above, wait for five seconds, then switch it on again.

When using the FSpO₂ monitor regularly, it is recommended to keep the rear switch in the “on” position and use the front switch to change from on to standby mode.

Telemetry System

The following table lists the signals at each pin. There is no external parameter input, no HR2 input and no US envelope input.

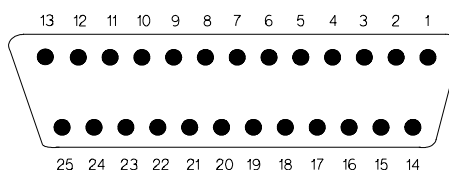

Figure 10-8 Telemetry System Pin Connections

Table 10-5 Telemetry System Pin Connections

Pin	Signal	Details
1	HR2 Input	Not connected (HR-LF2).
2	-12V Output	20mA maximum.
3	+5V Output	20mA maximum.
4	+12V Output	20mA maximum.
5	S1 Input	Telemetry On (L).
6	S2 Input	
7	S3 Input	DECG inop (L). (M1353A only.)
8	S4 Input	DECG Mode (L). (M1353A only.)
9	S5 Input	AECG Mode (L). Not currently used.
10	S6 Input	US Mode (L).
11	S7 Input	
12	S8 Input	IUP Mode (L). (M1353A only.)
13	S9 Input	Toco External Mode (L).
14	HR1 Input	HR-LF. US range: -3.5V to +3.5V. DECG range: -6V to +6V. $R_i: >82k\Omega$
15	Toco Input	Toco dc. Voltage range: -3V to +2V. Sensitivity: -1V full scale (-1V=+100 units). $R_i: >82k\Omega$

Table 10-5 Telemetry System Pin Connections

Pin	Signal	Details
16	Ext Par Input	
17	Gnd Analog	Signal Ground.
18	Gnd	
19	Mark (Input)	Tele-Marker on (L)
20	FMP on (Input)	Tele-FMP on (L)
21	FM (Input)	Tele-Fetal movement on (L)
22		Not connected
23	IF ID (Output)	Gnd (Not connected with Combined Interface Module "E")
24	Gnd	
25		Not connected (HR2 Mode).

Key: (L) means Logic input is low (0 Volts).

80235A (OBMS), M1370A (ODIS), and OB TraceVue

Table 10-6 lists the signals at each pin.

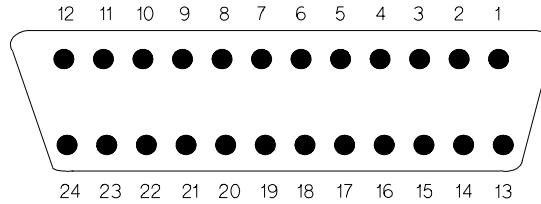

Figure 10-9 OBMS and ODIS Pin Connections

Table 10-6 OBMS and ODIS Pin Connections

Pin	Signal	Details
1	HR2 Output	1V/100bpm $\pm 40\text{mV}$ (0V if not valid). R_{out} : 100 Ω
2		Not connected.
3	RS422 Output +	Digital Serial Output. 1200 baud, 8 bit, no parity.
4	Toco Status Output	Toco External Mode or No Toco Mode (L). IUP Mode (H). R_{out} : 1.1k Ω , 100nF.
5	HR1 _{valid} Output	When heart rate is valid, output is high. R_{out} : 1.1k Ω , 100nF.
6		Not connected.
7		Not connected.
8	RS232 RxD	Digital Serial Input. RS232, 1200 Bd., 8 bit, no parity.
9	RS232 TxD	Digital Serial Output. RS232, 1200 Bd., 8 bit, no parity.
10		Not connected.
11	HR1 Mode Output	US: 0.6V, AECG: 5V, DECG: 6.7V, INOP: 8.5V. R_{out} : 38K Ω
12	Ground Analog	Signal Ground.
13	Toco Output	1V/10 Toco units $\pm 100\text{mV}$. R_{out} : 100 Ω
14	HR2 Mode Output	US: 0.6V, AECG: 5V, DECG: 6.7V, INOP: 8.5V. R_{out} : 38K Ω

Table 10-6 OBMS and ODIS Pin Connections

Pin	Signal	Details
15	RS422 Output -	Digital Serial Output. 1200 baud, complement.
16	0V Output	Connected to Ground.
17	RS422 Input +	Digital Serial Input: 1200 baud.
18	RS422 Input -	Digital Serial Input: complement.
19	Instrument On/Off	Not Connected.
20	Ext Marker Output	Digital Signal Output. 0V: On (>250ms). R _{out} : 1.1k Ω , 100nF.
21	HR1 Output	1V/100bpm \pm 30mV. R _{out} : 100 Ω Paper-out and HR-coincidence.
22	Ext Test Input	When input is low, external test is on. Internal pull-up resistance: 4.64k Ω
23	Monitor ID Output	2.0V regulated. R _i : 100 Ω (for Fetal Trace Transmission System).
24	Chassis Ground	RS232 signal ground.

Key (L)\means Logic input/output is low (0 V).

(H)\means Logic input is high (5 V).

In the event of a paper-out or an HR-coincidence, an analog signal is applied to pin 21. This lasts approximately 600 msec and is repeated every minute for as long as the condition remains. The exact output voltages are shown in Table 10-7.

Table 10-7 Pin 21: Output Voltage Values

Pin Voltage	Remarks
3.575	Normal operation.
3.725	Reserve.
3.875	Paper out.
4.025	Reserve.
4.175	Coincidence.
4.325	Reserve.
4.475	Coincidence and paper out.
4.625	Reserve.

Introduction

This chapter identifies the boards and replacement parts, giving their part numbers, and lists the tools needed to service the monitor. It then describes how to replace or disassemble the various parts. For most service tasks, it is not necessary to remove parts, and you should only disassemble the monitor as far as is necessary. Please note that the appearance of the monitor parts may differ slightly according to the revision.

Warning

Electrical power is dangerous. Before removing any parts from the monitor, the power to the monitor must be disconnected.

Ordering Parts

To order a part, contact your local Philips Medical Sales/Service Office, quoting the part number listed in the tables. To order a part not listed in the tables, give the following information:

- The model number of the monitor.
 - The complete serial number of the monitor.
 - A description of the part, including its function and location.
-

Warning

Occasionally, as well as markings indicating manufacture by Philips, electronic components will carry standard commercial identification numbers. These components have been selected to meet specific operational criteria. Using components purchased through normal commercial channels may result in degradation of the operation performance or the reliability of the monitor.

Safety Test Requirements

The test and inspection procedures which **must** be carried out after you install or carry out repairs on the fetal monitors are described in “Safety Testing” on page 100.

Service Tools

The basic tools you will need to service the Series 50 A and Series 50 IP-2 fetal monitors are:

- Small crosshead screwdriver
- Large crosshead screwdriver
- Medium slothead screwdriver
- Box screwdriver (HBA).

The following tools are useful but not essential:

- Universal vice (to hold the base plate)
- Small pincers or tweezers
- Digital Volt Meter
- Soldering Iron.

Lists of Parts

Boards

Please note that as the appearance of the boards varies slightly according to revision, your monitor may not look exactly like the monitors pictured.

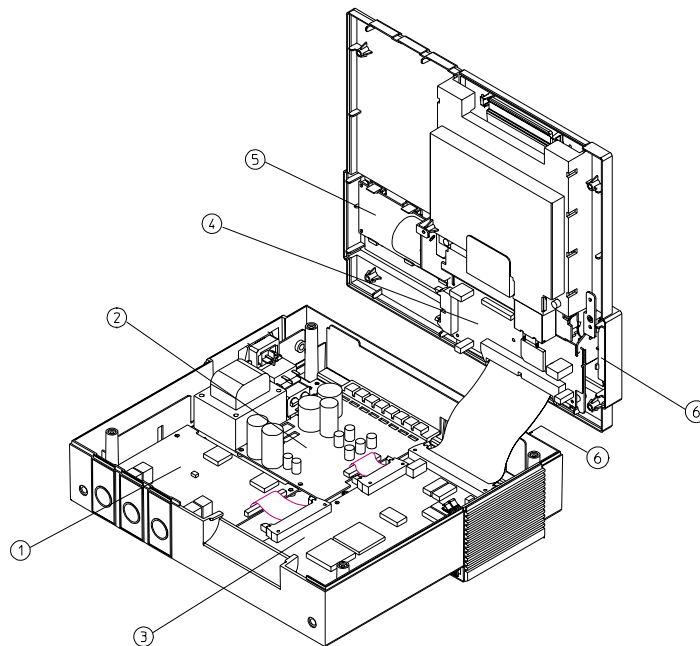

Figure 11-1 Boards

Table 11-1 Boards Parts List

Item	Description	Part Number	
		Old Identifier	New Identifier
1	M1351A Single Front End Board rectangular or triangular	M1353-69501	453563276301
	M1351A Twins Front End Board rectangular or triangular	M1353-69511	453563276331
	M1353A Front End Board IP (monitors with serial number prefix \leq 3652G)	M1353-69512	453563276341
	M1353A Front End Board XM (monitors with serial number prefix \geq 3720G), required for IP-2	M1350-69517 ¹	453563273701
2	Power Supply Board	M1353-69502	453563276311
3	CPU Board (for M1351A monitors with serial number prefix \leq 3604G, and M1353A monitors with serial number prefix \leq 3605G). This board requires a 4 Ohm speaker.	M1353-69503	453563276321
	CPU Board (for M1351A monitors with serial number prefix \geq 3651G and for M1353A monitors with serial number prefix \geq 3652G). This board requires a 8 Ohm speaker.	M1353-69513	453563276351
4	Recorder Interface Board	M1353-66510	453563276171
5	Display Board	M1353-66520	453563276211
6	Switch Board	M1353-66521	453563276221
	Combined Interface Board, Revision E	M1353-69531	453563276361
	Modem Interface Board	M1353-69532	451261001451

1. M1350-69517 needs firmware Rev. A.02.07 to be 100% compatible with M1353-69512.

Monitor Parts

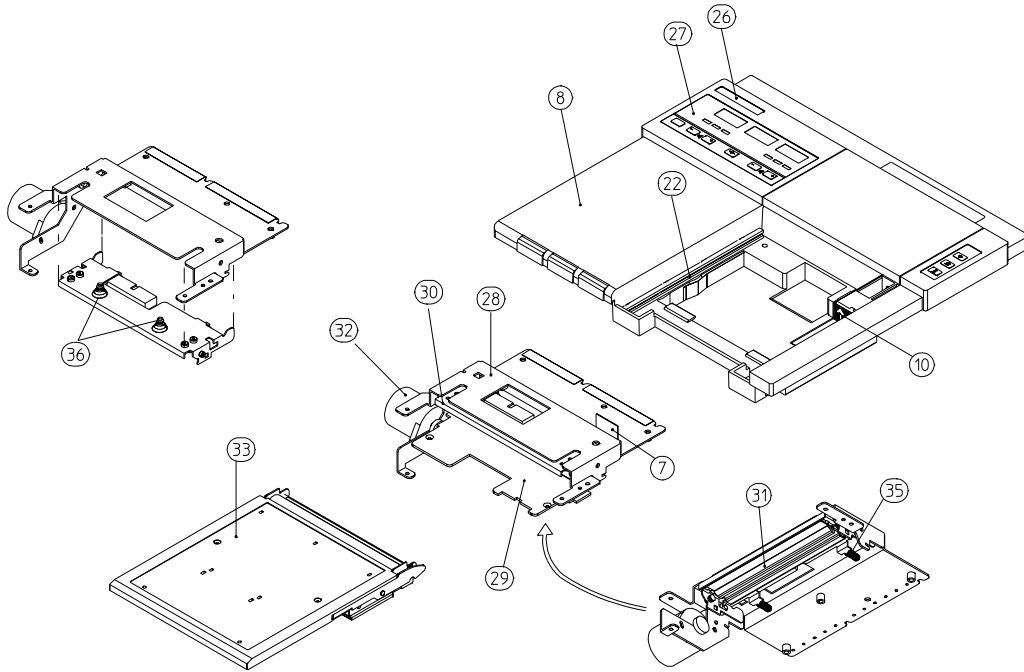

Figure 11-2 Monitor Parts Diagram (1 of 3)

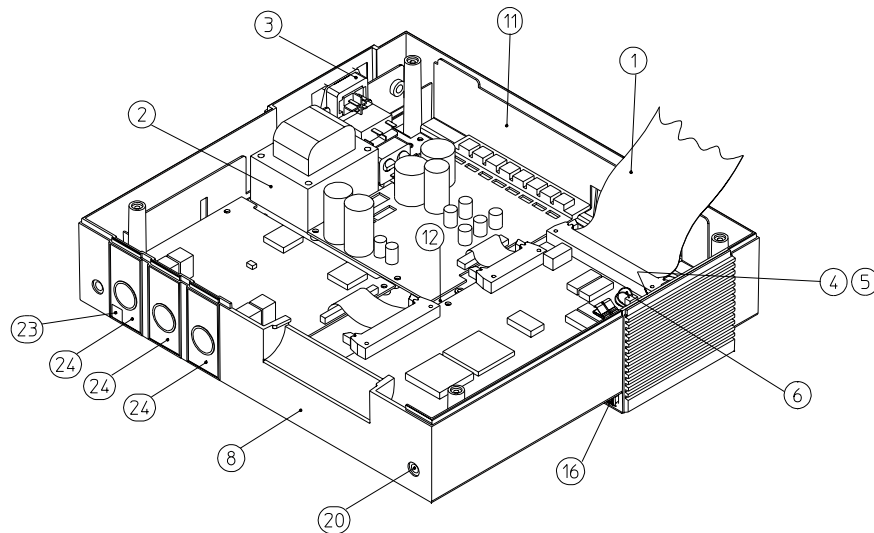

Figure 11-3 Monitor Parts Diagram (2 of 3)

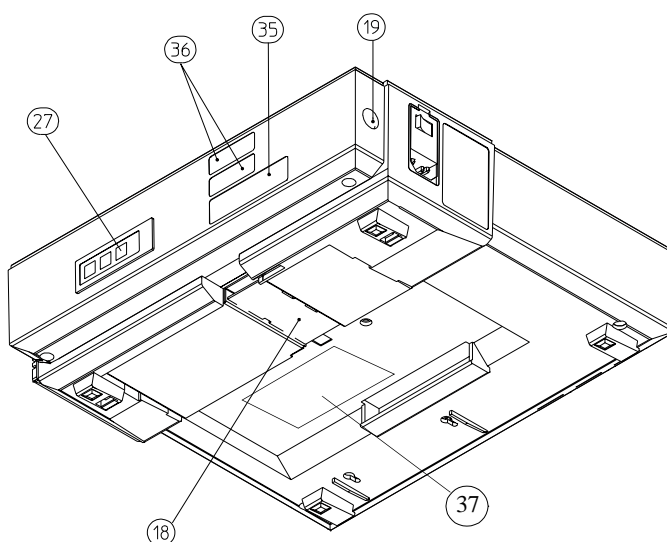

Figure 11-4 Monitor Parts Diagram (3 of 3)

Table 11-2 lists currently available monitor parts. If a part is still available in the older, darker gray color, this number is noted in the first part number column of this list.

Table 11-2 Monitor Parts List

Item	Description	Part Number				Qty
		Darker Color		Lighter Color		
		Old Identifier	New Identifier	Old Identifier	New Identifier	
1	Backplane Cable Assembly	-	-	M1353-61603	453563275981	1
2	110V Transformer 230V Transformer	-	-	9100-5007 9100-5008	453563202371 453563202381	1
3	Line Filter with switch	-	-	9135-0453	453563202541	1
4	Loudspeaker 4 Ohms (use with M1353-69503 CPU board)	-	-	9164-0342	453563202891	1
	Loudspeaker 8 Ohms with cable assembly	-	-	M1353-61615	453563276001	1
5	Loudspeaker O-Ring	-	-	M1350-42501	453563272631	1
6	Loudspeaker & Battery Cable Assembly	-	-	M1350-61603	453563273011	1
7	Recorder Sensing Assembly	-	-	M1353-66522	453563276231	1
8	Cover Kit (Top & Bottom)	M1353-64100	453563276031	M1353-64200	453563276101	1
-	Housing screws: x4 M3x6, x1 M3x12 (not shown)	-	-			
9	Barcode label for option J15	M1353-44312	453563275851	M1353-44362	453563275891	

Table 11-2 Monitor Parts List

Item	Description	Part Number				Qty
		Darker Color		Lighter Color		
		Old Identifier	New Identifier	Old Identifier	New Identifier	
10	Battery Compartment Cover	-	-	M1353-64114	453563276061	1
-	Battery Compartment and Cables	-	-	M1353-64115	453563276071	1
11	Chassis	-	-	M1353-00101	453563275701	1
12	Insulator	-	-	M1353-45401	453563275911	1
16	Foot repair kit (both colors)	M1353-67901	453563276261	M1353-67901	453563276261	
18	Interface Cable Cover	-	-	M1353-44117	453563275811	1
19	Ground Stud Washer for Ground Stud	-	-	1251-5964 2190-0676	453563470031 451261005901	1 1
23	Software configuration label	-	-	M1350-44306	453563272721	1
24	Front-End Connector Label	M1353-44304	453563275821	M1353-44354	453563275861	1
25	Power/Warning Label	M1353-44305	453563275831	M1353-44355	453563275871	1
26	Nameplate Label M1351A	M1353-44306	453563275841	M1353-44356	453563275881	1
	Nameplate Label M1353A	-	-	M1353-44365	453563275901	1
27	Overlay kit (M1351A Single) Overlay kit (M1351A Twins & M1353A)	M1353-60620 M1353-60621	453563275941 453563275951	M1353-60720 M1353-60721	453563275961 453563275971	1
28	Recorder Chassis ¹	M1353-00153	453563275721	M1353-00153	453563275721	1
29	RFI Bracket	-	-	M1353-01251	453563275731	1
30	Thermal Printhead Holder ¹	M1353-02353	453563275771	M1353-02353	453563275771	1
31	Thermal Printhead	-	-	1810-1421	453563064931	1
32	Stepper Motor	-	-	3140-0857	453563085111	1
33	Drawer Assembly ¹	M1353-64553	453563276121	M1353-64653 Enhanced version	453563276131	1
34	Conical Spring	-	-	1460-2338	453563058421	2
35	Warning Labels (not orderable)	-	-	5041-8183	453563100111	2
36	Label with Service Number and Option (not orderable)	-	-	NA	NA	1
-	Screw Hilo (display bd)	-	-	0624-0761	453563028431	2
37	Caution/ CE label (not on older models)	-	-	M1350-44322	453563272741	1
Replacement Part List						
	Cardio Input Connector (red)	-	-	1252-3461	453563050771	1
	TOCO Input Connector (brown)	-	-	1252-3462	453563050781	1

Table 11-2 Monitor Parts List

Item	Description	Part Number				Qty
		Darker Color		Lighter Color		
		Old Identifier	New Identifier	Old Identifier	New Identifier	
20 (on page 122)	Service Connector	-	-	1252-2702	453563050531	1
20 (on page 5)	Marker Input Connector	-	-	1252-2702	453563050531	1

1. See Figure 11-5 on page 126 for details of the differences between the two part numbers available.

Recorder Parts The following diagram shows you how to assemble the recorder using the older and newer parts. Please note that the older parts are no longer orderable. The sticker illustrating how to load paper is included in the recorder parts kit.

Item	Original Version	Enhanced Version
Recorder Chassis	M1353-00151 453563275711 (not orderable)	M1353A SN >=3327G00850 M1351A SN >= 3326G02782 M1353-00153 453563275721
Thermal Printhead Holder	M1353-02351 453563275761 (not orderable)	M1353-02353 453563275771
	(needs 4 springs)	(needs 2 springs)
Drawer Assembly	M1353-64551 453563276111 (not orderable)	M1353-64553 453563276121 (darker color) M1353-64653 453563276131 (new color)

Figure 11-5 Changes to the Recorder

Note— Original and enhanced versions of these parts are not interchangeable. All three parts can be assembled only if they are all the same version.

Monitor Housing Color

Table 11-3 Monitor Housings: Color Changes

Monitor	Old Color of Housing	New Color of Housing	Change of Color Effective from Serial Number...
M1351A	Parchment Grey	Arctic White	≥ 3816G12439
M1353A			≥ 3817G02995

Table 11-4 lists currently available miscellaneous parts. If a part is still available in the older, darker gray color, this number is noted in the first part number column of this list.

Table 11-4 Miscellaneous Parts List

Description	Part Number				Qty
	Darker Color		Lighter Color		
	Old Identifier	New Identifier	Old Identifier	New Identifier	
Angle Mount	M1353-63201	453563276011	M1353-63202	453563276021	1
Paper Take-Up (for table top and cart mountings)	-	-	M1353-02303	453563275751	1
Paper Take-Up (for the wall mount)	-	-	M1353-42302	453563275781	1
Wall mount Kit (without Paper Take-up)	-	-	M1353-64160	453563276091	1
Pair (1 Front and 1 Rear) Wheels for Cart CL (M1323A) Option 2AE	-	-	M1323-42075	453563272041	2
Front Wheel for Mobile Cart Option 1AE	-	-	80310-68707	453563197881	1
Rear Wheel for Mobile Cart Option 1AE	-	-	80310-68708	453563197891	1
Drawer Kit for Cart CL (M1323A) Option 2AE	-	-	M1323-68450	453563272051	1
Drawer Kit for Mobile Cart Option 1AE	-	-	M1307-68704	453563271641	1
Telemetry Mounting Plate for Cart	-	-	M1307-68705	453563271651	1
Maternal IF-cable	-	-	M1350-61609	453563273051	1
Barcode Reader Kit	-	-	M1350-68730	453563273561	1

**Toco
Transducer
(Blue, M1355A)**

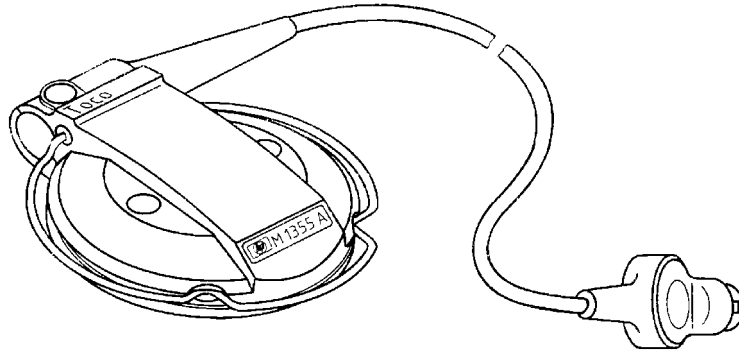

Figure 11-6 Toco Transducer

Table 11-5 Toco Transducer Parts List

Description	Part Number		Qty
	Old Identifier	New Identifier	
M1355A exchange transducer (2.5m)	M1355-69011	453563277171	1
M1355A blue transducer (2.5m)	M1355-60011	453563277131	1
M1355A exchange transducer (0.7m)	M1355-69013	453563277181	1
M1355A blue transducer (0.7m)	M1355-60013	453563277141	1

Caution

All BLUE M1355A, M1356A and M1358A transducers are sealed, watertight units and are NOT repairable. Replacing the cable of a blue transducer, or modifying the transducer in any way, will void any warranty, including the guarantee of watertightness.

Ultrasound Transducer (Blue, M1356A)

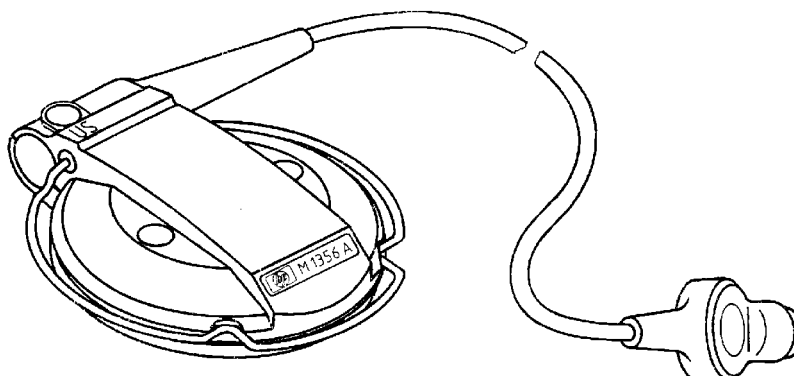

Figure 11-7 Ultrasound Transducer M1356A (Blue)

Table 11-6 Ultrasound Transducer M1356A (Blue)

Description	Part Number		Qty
	Old Identifier	New Identifier	
M1356A exchange transducer (2.5m)	M1356-69011	453563277271	1
M1356A blue transducer (2.5m)	M1356-60011	453563277241	1
M1356A exchange transducer (0.7m)	M1356-69013	453563277281	1
M1356A blue transducer (0.7m)	M1356-60013	453563277251	1

Caution

All BLUE M1355A, M1356A and M1358A transducers are sealed, watertight units and are NOT repairable. Replacing the cable of a blue transducer, or modifying the transducer in any way, will void any warranty, including the guarantee of watertightness.

**DECG
Transducer
(M1357A)**

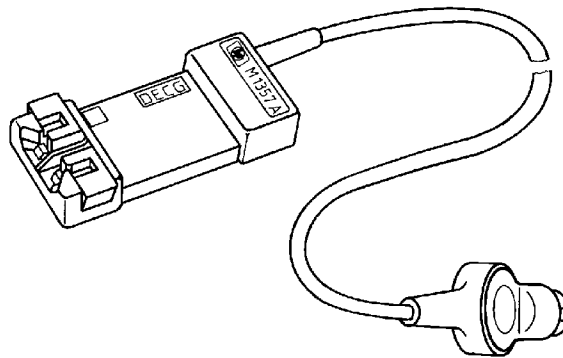

Figure 11-8 DECG Transducer M1357A

Table 11-7 DECG Transducer: Parts List

Description	Part Number		Qty
	Old Identifier	New Identifier	
M1364A Patient Module (use with M1362B)	M1364-69001	453563277471	1
M1362B DECG Adapter Cable	M1362B	989803103551	1

Table 11-8 DECG Cable Connections

Pin	Wire Color (Old)	Wire Color (New)
2	Yellow	Red
5	Green	Brown
1+6	Bridged by Code Resistor 4.53 k Ω (\pm 1%)	
1	Shield	

**MECG
Transducer
(M1359A)**

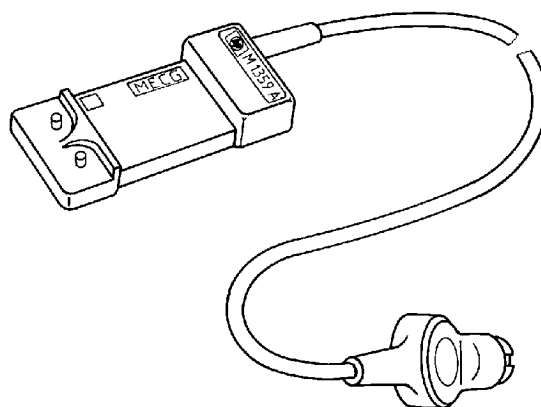

Figure 11-9 MECG Transducer M1359A

Table 11-9 MECG Transducer: Parts List

Item	Description	Part Number		Qty
		Old Identifier	New Identifier	
-	M1364A Patient Module (use with M1363A)	M1364-69001	453563277471	1
-	M1363A MECG Cable	M1363A	989803103561	1

Table 11-10 MECG Transducer Cable Connections

Pin	Wire Color (Old)	Wire Color (New)
2	Yellow	Red
8	Green	Brown
1+6	Bridged by Code Resistor 12.4kΩ (± 1%)	
1	Shield	

Toco Transducer (Brown)

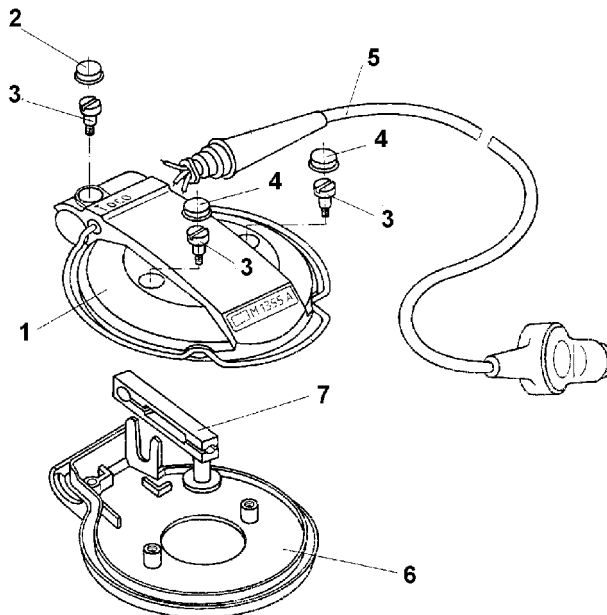

Figure 11-10 Toco Transducer (Brown)

Table 11-11 Toco Transducer: Parts List

Item	Description	Part Number		Qty
		Old Identifier	New Identifier	
-	Complete Transducer (Toco, Blue)	M1355-60011	453563277131	1
1	Case Top (Toco, Black)	M1355-44552	453563277111	1
2	Cover Screw (Brown)	M1355-44105	453563277091	1
3	Screw	0515-2121	453563024231	3
4	Cover Screw (Black)	5041-4274	453563099961	2
5	Cable Assembly (Toco)	M1355-61652	453563277161	1
6	Case Bottom (Toco)	M1355-44551	453563277101	1
7	Strain Gauge	0960-0810	453563045191	1
-	Transducer Knob Adapters (not shown)	M1356-43203	453563277201	3

Table 11-12 Toco Transducer Cable Connections

Pin	Wire Color	Strain Gauge
2	Yellow	2
3	Green	4
4	Blue	1
8	Orange	3
1+6	Bridged by Code Resistor 4.53k Ω (\pm 1%)	
1	Shield	

Caution

Older BROWN transducers can be repaired, but all BLUE M1355A, M1356A and M1358A transducers are sealed, watertight units and are NOT repairable. Replacing the cable of a blue transducer, or modifying the transducer in any way, will void any warranty, including the guarantee of watertightness.

Caution

DO NOT use a screwdriver or similar flat-bladed instrument to separate the transducer covers as this can damage the seals and cause leakage when the transducer is re-assembled. Take care when removing the wires as they are thin and can easily be damaged. NEVER pull the strain gauge button.

1. Disconnect the transducer from the monitor.
2. Remove screw covers **2** and **4**: press a flat screwdriver into the covers and prise them out.

Note— When reassembling the transducer, you will need new screw covers as the old ones cannot be re-used.

3. Partially undo screws **3**. The two halves of the transducer can now be separated by pressing down on the screws.
4. Remove the screws **3** and pull the two halves of the cover apart.
5. Disconnect the transducer cable from the strain gauge **7**: use a soldering iron to separate the three cable wires from the gauge.
6. Cut the clips holding the strain gauge and remove it.

Re-assembly is a reversal of the above procedure. The strain gauge assembly is a press fit into the transducer cover.

Ultrasound Transducer (Brown)

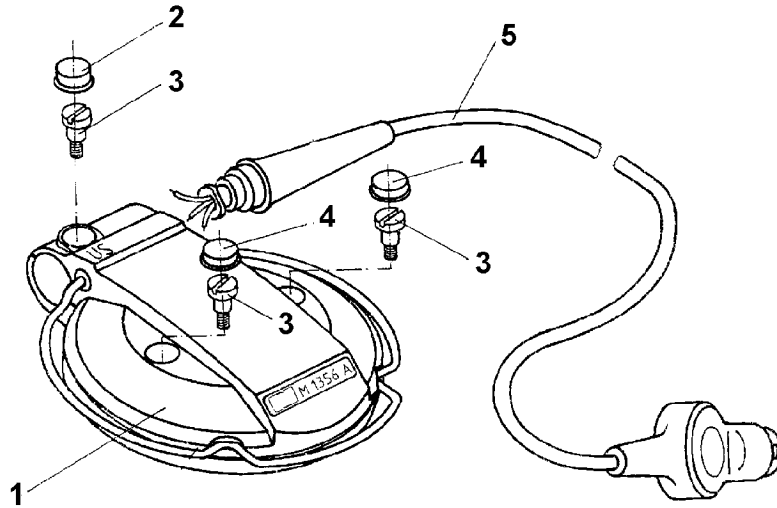

Table 11-13 Ultrasound Transducer: Parts List

Item	Description	Part Number		Qty
		Old Identifier	New Identifier	
-	Complete Transducer (US, Blue)	M1356-60011	453563277241	1
1	Case Top (US, Black)	M1356-44562	453563277221	1
2	Cover Screw (Red)	M1356-44106	453563277211	1
3	Screw	0515-2121	453563024231	3
4	Cover Screw (Black)	5041-4274	453563099961	2
5	Cable Assembly (US)	M1356-61661	453563277261	1
-	Transducer Knob Adapters (not shown)	M1356-43203	453563277201	3

Table 11-14 Ultrasound Transducer Cable Connections

Pin	Wire Color
4	Brown
8	Red
1+6	Bridged by code resistor 665 Ω (\pm 1%)
1	Shield

Caution

Older BROWN transducers can be repaired, but all BLUE M1355A, M1356A and M1358A transducers are sealed, watertight units and are NOT repairable. Replacing the cable of a blue transducer, or modifying the transducer in any way, will void any warranty, including the guarantee of watertightness.

Caution

DO NOT use a screwdriver or similar flat-bladed instrument to separate the transducer covers as this can damage the seals and cause leakage when the transducer is re-assembled. Take care when removing the wires as they are thin and can easily be damaged.

1. Disconnect the transducer from the Monitor.
2. Remove screw covers 2 and 4: press a flat screwdriver into the covers and prise them out.

Note— When reassembling the transducer, you will need new screw covers as the old ones cannot be reused.

3. Partially undo screws 3. The two halves of the transducer can now be separated by pressing down on the screws.
4. Remove the screws 3 and pull the two halves of the cover apart.
5. Disconnect the transducer cable from the crystal board: use a soldering iron to separate the three cable wires from the board.

Re-assembly is a reversal of the above procedure.

Caution

The use of ultrasound gel that is not approved by Philips may reduce signal quality and may damage the transducer. This type of damage will not be covered by warranty.

Patient Module (M1364A)

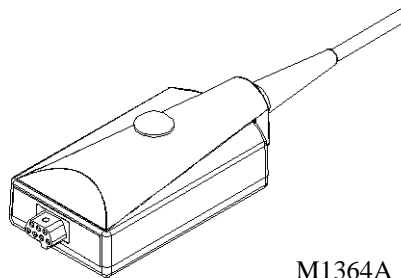

M1364A

Parts List

Table 11-15 Parts List

Item	Description	Exchange Part Number		New Part Number		Qty
		Old Identifier	New Identifier	Old Identifier	New Identifier	
2	ECG-only Patient Module	M1364-69001	453563277471	M1364-60001	453563277411	1
3	DECG Cable	-	-	M1362B	989803103551	1
4	MECG Cable	-	-	M1363A	989803103561	1

Troubleshooting The only functional checks that can be carried out on the patient modules and cables are those outlined in “Testing Patient Modules (M1364A)” on page 99.

Fuses

The fuse values are printed beside the mains socket:

For 100-120V Line Voltage T500mA/250V

For 220-240V Line Voltage T250mA/250V

To replace the fuses:

1. Switch off the monitor and disconnect it from the main power supply.

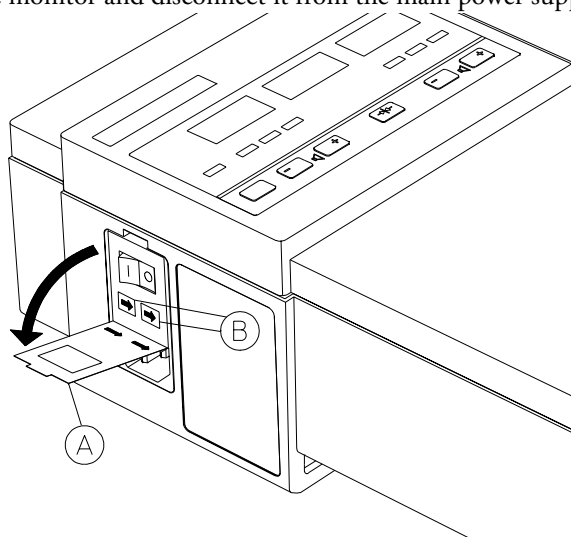

2. Using a flat-bladed screwdriver, prise open the fuse cover.
3. Lift the fuse holder slightly and pull it out.
4. Remove the fuse from the holder and replace it with another of the correct value.
5. Slide the holder back into place, aligning the arrow on the holder with the arrow on the cover.
6. Repeat steps 3, 4 and 5 for the second fuse.
7. Close the fuse cover.

Batteries

If the batteries are not replaced when necessary, the time and date return to their default values: when you switch on the Monitor the time is set to 0:00 and date to 04:04:44. Replace batteries with two alkaline AA size 1.5 Volt batteries (recommended type Duracell AA 1.5 Volt Part Number 1420-0393CP). Follow these instructions to replace the batteries:

1. Switch off the Monitor and disconnect it from the main power supply.
2. Press the handle of the paper table and open it by pulling the table forward - lift out any paper.
3. Open the battery cover.

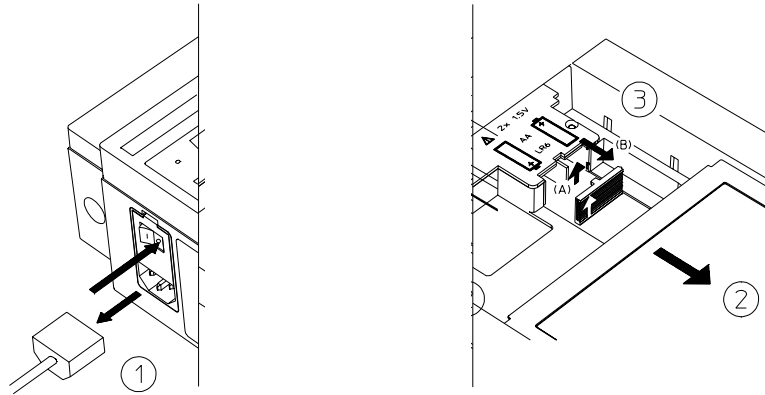

4. Replace the batteries (noting their polarity).
5. Close the battery cover, load paper into the tray and push the paper table closed.
6. Reset the time and date (see Chapter 5, “Setting Time, Date, and Paper Speed.”).

Top Cover

To remove the top cover:

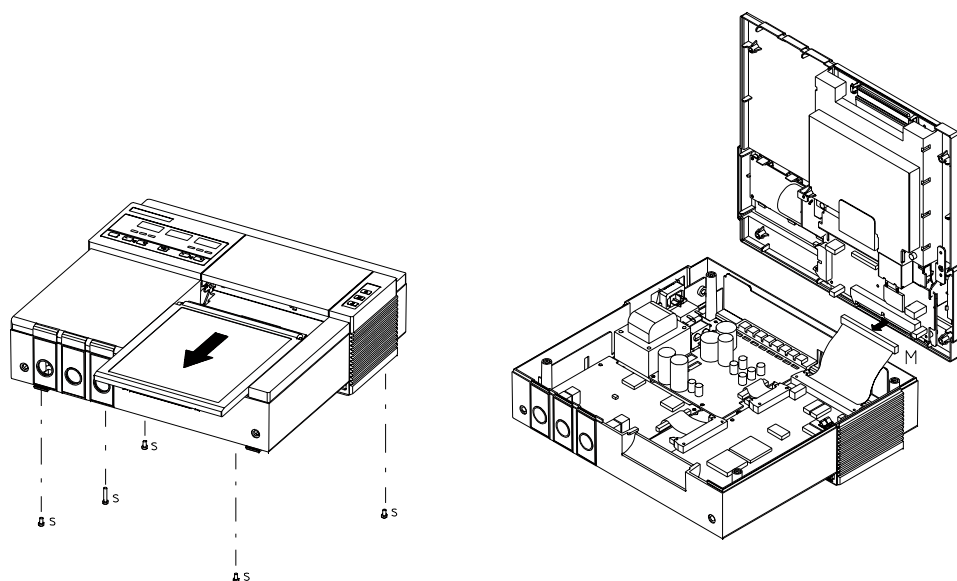

Figure 11-11 Removing the Top Cover

1. Switch off the Monitor and disconnect the power cable; then remove the board.
2. Remove the five screws (S).
3. Open the paper table.
4. Lift off the top cover.

Caution

If you need to remove the cable (M), the battery supply is also disconnected from the CPU Board. Data stored in the battery-buffered RAM will be lost.

5. Disconnect the cable (M) if necessary.

To refit the cover, reverse the above procedure.

Front End Board

To remove the board:

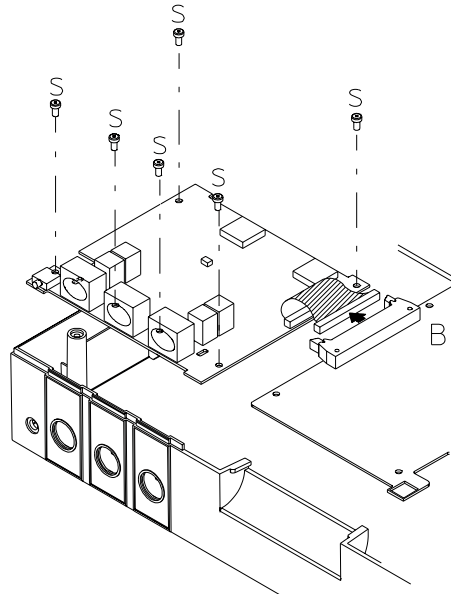

The illustration above shows removal of a rectangular shaped board. The replacement board is triangular in shape. The design change does not affect the positioning or function of the board.

Remove the top cover.

1. Disconnect the cable (B).
2. Remove the screws (S).
3. Gently pull the front panel a little to give enough room.
4. Lift out the board.

To refit the board, reverse the above procedure. If you are replacing Front End Board M1353-69512 with M1350-69517, the transparent plastic cover above the CPU board will not fit. This cover is no longer necessary. You may discard it.

Note— Before tightening the screws to secure the Front End Board, slide the board as far as possible toward the front of the unit. This ensures that the connectors are in their correct positions.

Carry out the Parameter Test (see page 68).

Power Supply Board

To remove the power supply board:

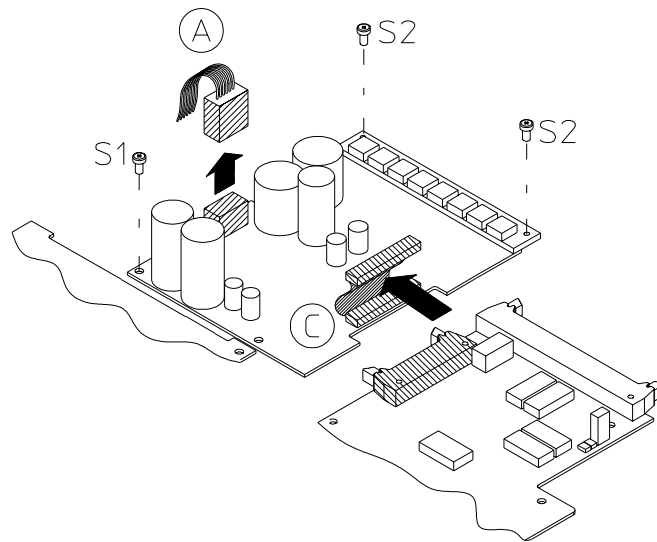

1. Remove the top cover.
2. Disconnect the cables (A and C).
3. Remove the three screws (S). The S2 screws are longer than the S1 screws.
4. Lift out the board.

To refit the board, reverse the above procedure. After refitting the board, carry out the Parameter Test (see page 68).

Table 11-16 Fuse Part Numbers

	All Fuses
630 mA	2110-0895

CPU Board

To remove the CPU board:

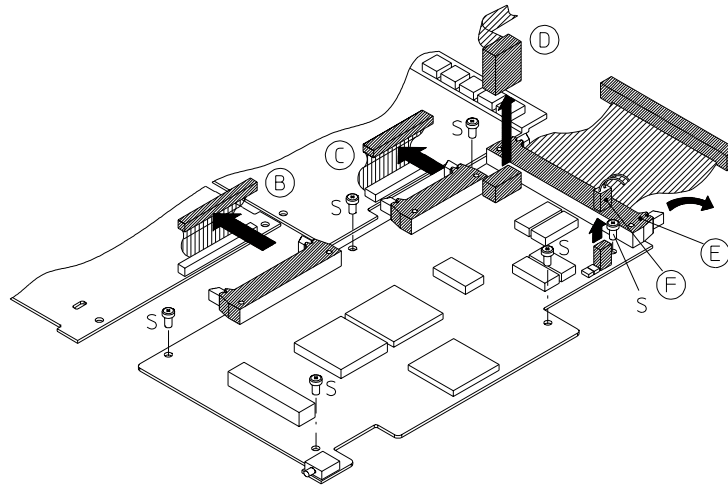

1. Remove the top cover.
2. Disconnect the cables (B, C, D, E and F).
3. Remove the six screws (S).
4. Lift out the board.

To refit the board, reverse the above procedure. After refitting the board, carry out the Parameter Test.

Do not forget to program the serial number into the new CPU board using the service software. See “Writing/Resetting the Serial Number and Setting the Options” on page 41.

Combined Interface Module

To remove the interface module:

1. Remove the retaining screw.
2. Slide the module out of the slot.

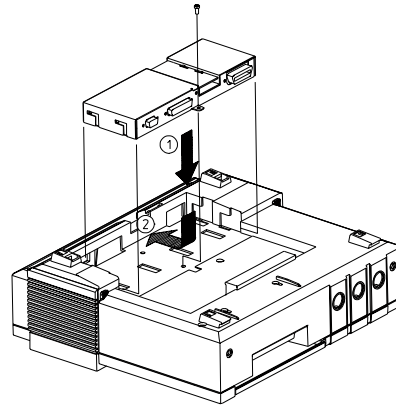

Refitting the interface module is the reverse of the above.

Modem Interface Module

To remove the modem interface module:

1. Remove the retaining screw.
2. Slide the module out of the slot.

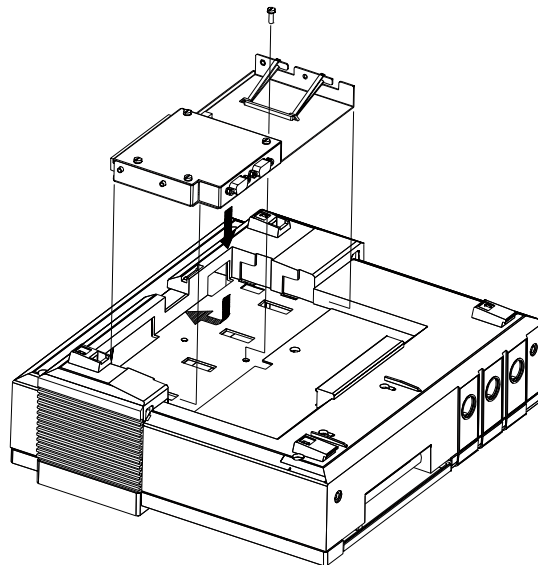

Chassis

To remove the chassis:

1. Remove the top cover.
2. Remove the combined interface board - if installed.
3. Remove the Front End Board.

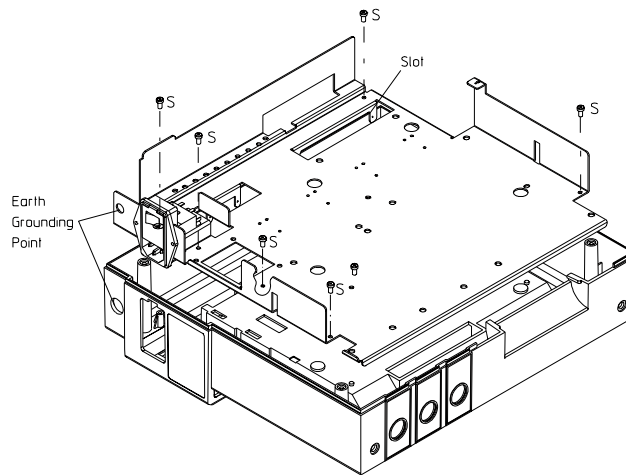

4. Remove the six screws (S).
5. Remove the nut from the Earth Grounding Point.
6. Lift out the chassis.

To refit the chassis, reverse the above procedure. Remember to feed the cable from the rear display board through the slot in the back of the chassis. After refitting the chassis, carry out the Parameter Test (see page 68).

On/Off Switch

To remove the monitor on/off switch:

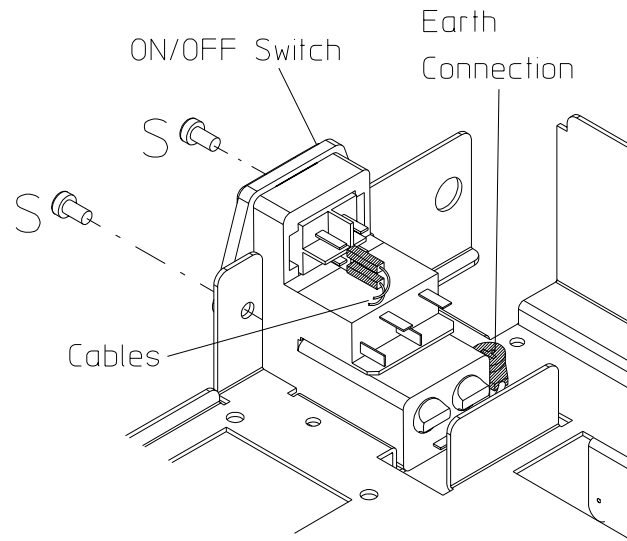

1. Remove the chassis.
2. Remove the two screws (S).
3. Remove the earth connection.
4. Disconnect the two cables from the transformer.

To refit the switch, reverse the above procedure. After refitting the switch, carry out the Parameter Test (see page 68).

Recorder Board

To remove the recorder board:

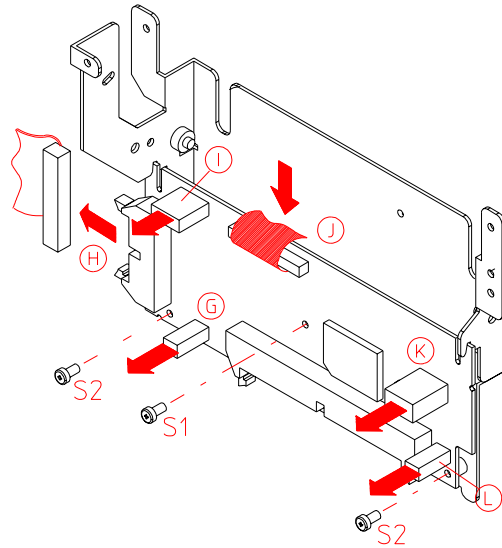

Remove the top cover.

1. Disconnect the cables G, H, I, K, and L.
2. Remove the three screws (1 x S1, 2 x S2). The S2 screws are longer than the S1 screw.
3. Remove the cable J.
4. Lift out the board.

To refit the recorder board:

1. Slide the board into the slot. To give a good electrical contact, the board is tensioned when screwed down.
2. Refit the screws and screw down the board.

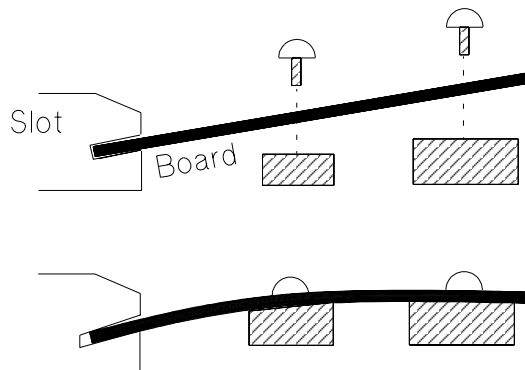
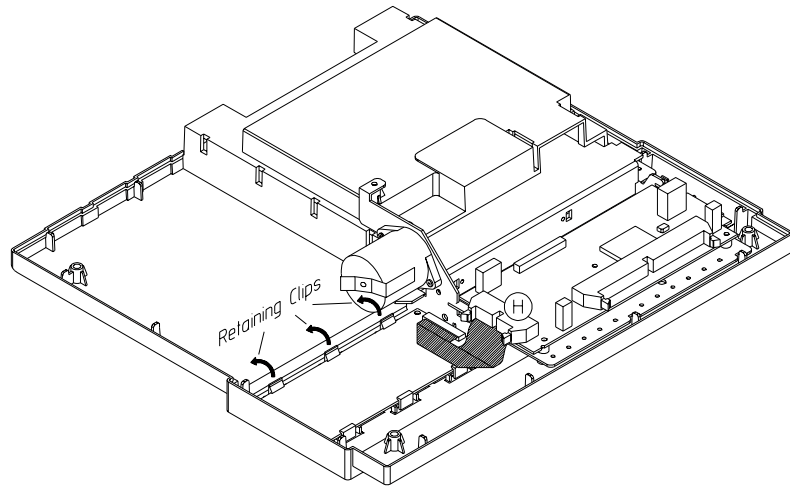

Figure 11-12 Refitting the Recorder Board

After refitting the board, carry out the Parameter Test (see page 68).

Display Board

To remove the display board:



1. Remove the top cover.
2. Disconnect the cable (H).
3. Remove the two screws.
4. Prise open the retaining clips and lift out the board.

To refit the board, push it into place and refit the screws. Reconnect cable and refit the top cover. After refitting the board, carry out the Parameter Test (see page 68).

Switch Board

To remove the switch board:

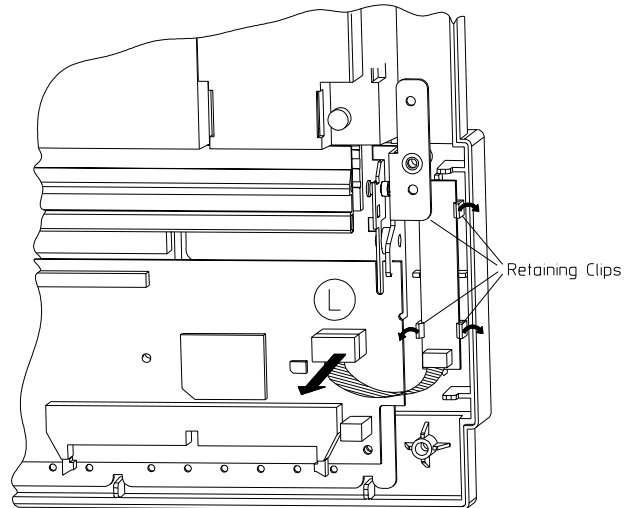

1. Remove the top cover.
2. Disconnect the cable (L).
3. Prise open the retaining clips and lift out the board.

To refit the board, push it into place (where it is held by the retaining clips), reconnect cable and refit the top cover. After refitting the board, carry out the Parameter Test (see page 68).

Loudspeaker

To remove the loudspeaker:

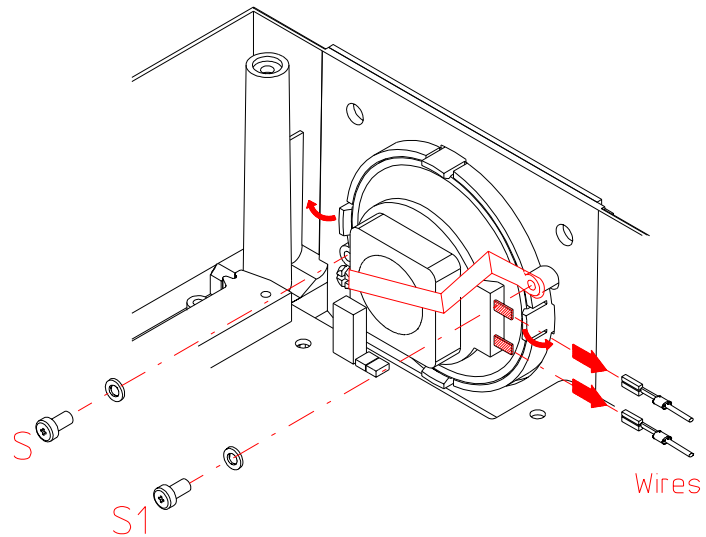

1. Remove the top cover.
2. Disconnect the two wires from the loudspeaker.
3. Remove the single screw (S1).
4. Remove the screw securing the loudspeaker bracket, and slide the bracket away from the speaker.
5. Lift out the loudspeaker.

To refit the loudspeaker, reverse the above procedure. After refitting the loudspeaker, carry out the Parameter Test (see page 68).

Transformer

To remove the transformer:

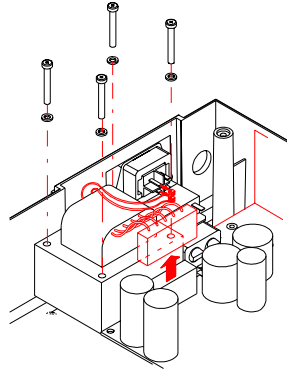

1. Remove the top cover.
2. Disconnect the three wires from the On/Off Switch.
3. Disconnect the cable from the Power Supply Board.
4. Remove the four screws and washers (S).
5. Lift out the transformer.

To refit the transformer, reverse the above procedure. After refitting the transformer, carry out the Parameter Test (see page 68).

Drawer Assembly

To remove the drawer assembly:

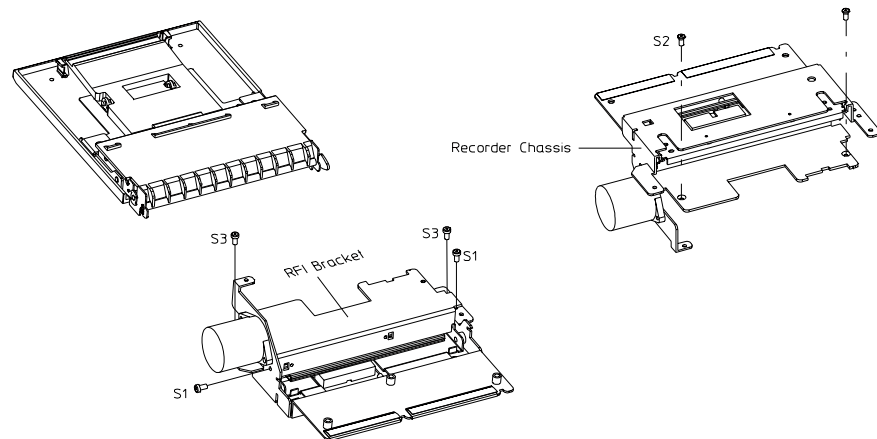

Figure 11-13 Removing the Paper Table

1. Remove the top cover and the Recorder Board.
2. Place the cover with the paper table facing upwards and slide back the drawer assembly.
3. Remove the two countersunk screws (S2).
4. Turn over the cover and place it so that the stepper motor is on the left and facing upwards.
5. Remove the RFI bracket:
 - a. Remove the two screws (S1 - one on left side, one on right side).
 - b. Pull up and lift out the RFI bracket (it is fitted with a lug).
6. Remove the recorder chassis:
 - a. Remove the two screws (S3 - one on left side, one on right side).
 - b. Lift out the recorder chassis.
7. Slide the paper table through the gap exposed by the recorder chassis.

To refit the paper table, reverse the above procedure taking note of the following:

Secure the two countersunk screws (accessed from top cover) before securing the recorder-chassis screws.

After refitting the paper table, carry out the System Test (see page 105).

Caution

The use of recorder paper that is not approved by Philips can damage the Monitor. This type of damage will not be covered by warranty.

Note— For more detailed illustrations of the enhancements to the recorder, see Figure 11-5, “Changes to the Recorder” on page 126.

Thermal Printhead

Before you can remove the thermal printhead, you must first remove the top cover, Recorder Board, and the recorder chassis:

1. Remove the top cover and the Recorder Board.
2. Place the cover with the paper table facing upwards and slide back the drawer assembly.
3. Remove the two countersunk screws (S2 Figure 11-13).
4. Turn over the cover and place it so that the stepper motor is on the left and facing upwards.
5. Remove the RFI bracket:
 - a. Remove the two screws (S1 in Figure 11-13).
 - b. Prise up and lift out the RFI bracket (it is fitted with a lug).
6. Remove the recorder chassis:
 - a. Remove the two screws (S3 in Figure 11-13).
 - b. Lift out the recorder chassis.

To remove the thermal printhead:

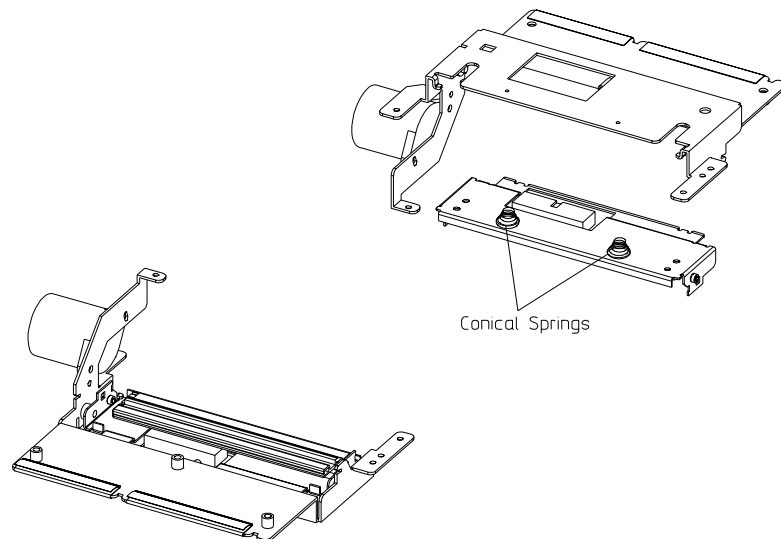

1. Place the recorder chassis so that the stepper motor is on the left and facing upwards.
- Note— Sandwiched between the printhead and its bracket are two conical springs. Therefore, be careful when doing the next step that the springs do not jump out.**
2. Gently, slide the printhead towards you and remove the springs.
 3. Turn over the printhead assembly and remove the four screws to release the printhead.

Caution

Take care not to touch the surface of the printhead or to lose the springs.

To replace the thermal printhead:

1. Loosely, secure the new printhead to its holder with the four screws.
2. Tighten the two screws at the front first (opposite side to cable connector), then the remaining two screws.
3. Refit the conical springs - you may need to open them a little and hook them into the recesses in the thermal printhead holder.
4. Position the printhead holder over the spacer slots of the recorder chassis, press down

and slide it into position.

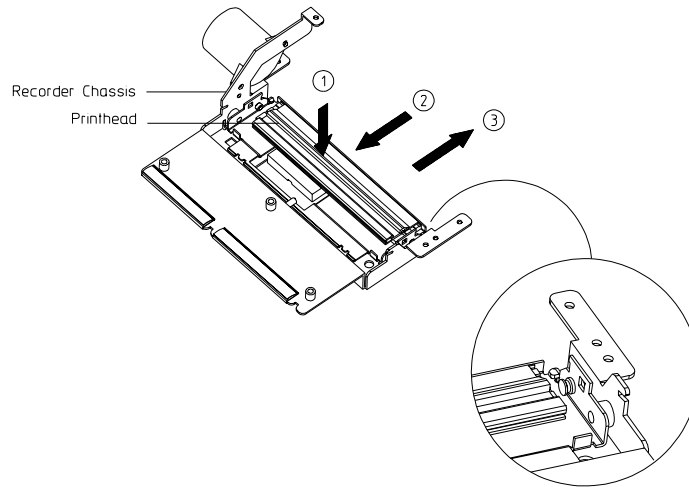

5. Refit the recorder chassis into the top cover.
6. Refit the RFI bracket.
7. Refit the countersunk screws.
8. Reconnect the printhead connector.
9. Refit the recorder board.
10. Reconnect the recorder-board cables.

Note— Do not fit a screw into the vacant screw position near the stepper motor. This screw position is reserved.

After replacing the thermal printhead, carry out the System Test (see page 105).

Recorder Sensing Assembly

To remove the recorder sensing assembly:

1. Remove the top cover and Recorder Board.
2. Remove the RFI bracket.
3. Remove the screw securing the recorder sensing assembly.
4. Disconnect the cable.

To refit the recorder sensing assembly, reverse the above procedure.

Caution

The use of recorder paper that is not approved by Philips can damage the Monitor. This type of damage will not be covered by warranty.

Stepper Motor

To replace the stepper motor:

1. Remove the two screws securing the stepper motor to the recorder chassis.
2. Replace the stepper motor.
3. Refit screws but do **not** tighten! The upper slot on the stepper motor allows fine adjustment when meshing the gears together.
4. Close the drawer assembly.
5. **Gently**, mesh the stepper-motor gear with that of the paper roller.

Caution

Do not press the gears together or exert any pressure on the stepper-motor spindle.

When in place, tighten the two screws.

Stepper Motor

A

Modem Interface Module

Introduction

The modem interface module allows fetal trace information to be transmitted from a Series 50 A/IP-2 Fetal Monitor to a receiver that is part of an OB **TraceVue** system.

The modem interface module (with the addition of an approved PCMCIA modem) enables fetal traces to be transmitted over a standard telephone line. The receiver software displays the trace information, allowing it to be reviewed, printed and stored.

Warning

To avoid possible electrical hazards:

Whenever a patient is connected to the fetal monitor the cable to the telephone system must be disconnected.

Never touch open contacts on the cable which is connected to the telephone system.

Fitting the Modem Interface Module

To connect the modem interface module:

1. Remove the cover (or any other interface module) from the Interface Socket on the monitor.
2. Connect the modem interface module to the Interface Socket.
3. Once the module is fitted, secure it in position by fixing it to the base of the monitor with the screw provided.

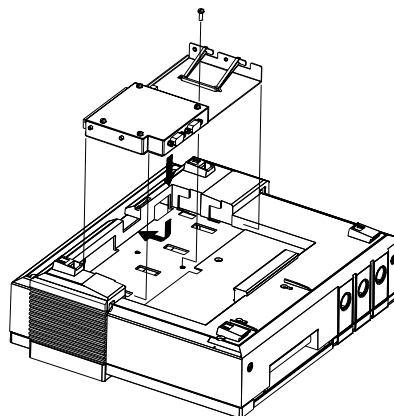

Figure 11-14 Fitting the Modem Interface Module

Connecting Peripheral Devices

After you have fitted the module, connect the following peripheral devices:

1. Connect the barcode reader to the module's RS232 interface socket (1). (The auxiliary serial port (2) allows connection to a PC but has no Philips software support.)
2. If necessary, connect a phone-line adapter and secure it to the module with cable fasteners or Velcro-type strip.
3. Checking it is the correct way up, insert a Philips approved PCMCIA card modem into the card connector port (3), pushing it until it is slotted in position.
4. Following the telephone connection recommendations given by the PCMCIA card modem manufacturer and your local telephone company, connect the socket at the rear of the PCMCIA card modem, or phone-line adapter to the telephone wall jack.

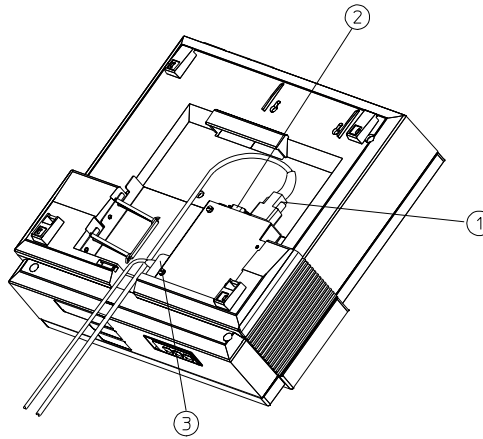

Figure 11-15 Connecting Peripheral Devices

Barcode Reader Interface

Once the barcode reader is installed, check that it is operating correctly. See the User's Guide for your monitor for instructions on how to use the barcode reader.

1. Use the barcode reader to scan **Test Barcode 1** and then **Test Barcode 2** from the barcode sheet.
2. Check that **TEST OK5** is printed on the paper. If it is not, switch the monitor off and on, and repeat the test. If it is still not printed, connect a new barcode reader.

The barcode reader interface has voltage levels of $\pm 12V$, 9600bd, max.1 byte/20 ms. The connector is a female D-type, 9-pin subminiature connector.

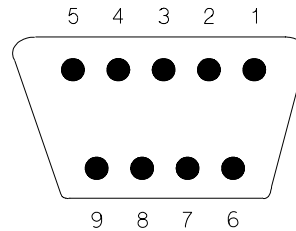

The following table lists the signal at each pin:

Pin	Signal	Details
1	CD	Carrier detect (connected to pin 4)
2	I: RxD	Receive data from external devices
3	I: TxD	Transmit data to external devices
4	DTR	Data Terminal Ready (connected to pin 1)
5	Gnd	RS232 Gnd
6	-	Not connected
7	B_Gnd	Barcode Reader Gnd
8	-	Not connected
9	B_Vcc	Barcode: +5V, 10mA (idle) to 35mA (configure)

The supply current to pin 9 depends on the modem card connected to the PCMCIA interface port; up to 300mA maximum. To ensure the correct power-on sequence for the Barcode Reader, pin 9 of the interface is switched on only when the monitor's power supply has stabilized.

RS232 Serial Interface

This RS232 Serial Interface connection enables the monitor to be connected to a PC (no Philips software supplied). The connector is a female D-type, 9-pin subminiature connector with a baudrate of 9600.

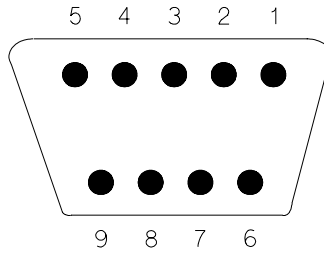

The following table lists the signals at each pin.

Pin	Signal	Details
1	I: DCD	Data carrier detect
2	I: RxD	Receive data from external devices
3	I: TxD	Transmit data to external devices
4	O: DTR	Data Terminal Ready
5	Gnd	RS232 Gnd
6	-	Not connected (I: DSR)
7	O: RTS	Request to send (connected to pin 8)
8	I: CTS	Clear to send (connected to pin 7)
9	-	Not connected (O: Ring)

Entering, Storing, and Transmitting Data

Actions associated with the storage and transmission of fetal trace information are initiated by using a barcode reader. Use the reader for:

- Entering the receiver phone number.
- Entering the patient phone number.
- Entering the patient ID.
- Clearing stored fetal trace data.
- Starting storage of the patient's fetal trace.
- Displaying the amount of minutes of fetal trace data stored in the memory.
- Transmitting stored data.
- Stopping the storage and transmission of data.

You must enter the receiver phone number. You should also enter at least either the patient phone number, or the patient ID.

- The *Receiver Phone*: provides a destination (receiver location) for the modem to transmit its fetal trace data to. If the receiver telephone number doesn't change, this information needs to be entered only once.
- The *Patient Phone*: aids in the correct assignment of the transmitted fetal data to the patient's file. It also enables the receiver to phone the patient's location and provide or request information. This information must be updated for each new patient. It is not essential, but highly recommended.
- The *Patient ID*: aids in the correct assignment of the transmitted fetal data to a patient's file by giving each patient a unique (alphanumeric) identity code. This information must be updated for each new patient.

Once this information has been entered successfully, the storage and transmission of fetal trace data can take place.

Note— All the barcodes you need to use this remote monitoring facility are on the sheet of barcodes supplied with the modem interface module. The sheet has two sides, one side is called Patient Identification, the other is called Entering Telephone Numbers. This sheet is NOT part of the Series 50 Fetal Monitors Nursing/Midwife Notes package.

Setting the Receiver Phone Number

To enter the *Receiver Phone* number (maximum of 20 characters):

1. Scan the *Receiver Phone* Barcode.
2. The telephone network will use a **Pulse** or **Tone** based switching system. Determine which is used (consult your local phone company for information), then first enter the appropriate *Pulse* or *Tone* barcode before scanning the digits of the Receiver Phone number.
3. From the numeric barcode list, scan each of the numbers that form the receiver phone number. If appropriate, remember to begin with whatever prefix necessary to get an outside line.
4. Scan the *Enter* barcode to store the information (automatic entry of scanned data after 15s).

If an error is made while entering information, scan the *Cancel* barcode to clear the data and start the process again from the beginning.

Note— If the recorder is running before you enter the *Receiver Phone* information Rec.Phone: and the telephone number will be printed on the recorder paper.

Setting the Patient Phone Number

To enter the *Patient Phone* number (maximum of 20 characters):

1. Scan the *Patient Phone* barcode.
2. From the numeric barcode list, scan each of the numbers that form the patients phone number.
3. Once this is finished, scan the *Enter* barcode to store the information (information is automatically 'entered' after 15 seconds).

If an error is made while entering information, scan the *Cancel* barcode to clear the data and start the process again from the beginning.

Note— If the recorder is running before you enter the *Patient Phone* information, Pat. Phone: and the telephone number is printed on the recorder paper.

Setting the Patient ID

The *Patient ID* (maximum of 16 characters) can consist of either letters, numbers, or a combination of both (alphanumeric). You could use the patient's name as the *Patient ID*. To enter the *Patient ID*:

1. Scan the *Patient ID* barcode.
2. Using the alphanumeric barcode list, scan each of the letters or numbers that form the *Patient ID*.
3. Once this is finished, scan the *Enter* barcode to store the information (information is automatically 'entered' after 15 seconds).

If an error is made in entering information, scan the *Cancel* barcode to clear the data and start the process again from the beginning.

Note— If the recorder is running before you enter the *Patient ID* information, Pat ID: and the ID number will be printed on the recorder paper.

When you send a trace you input patient identification data, you can choose whether you want the Monitor to retain all the patient identification data you input, after her trace is transmitted and the memory cleared, or whether you prefer to clear the patient data at the same time you clear the memory.

Keep Patient Data after Transmission or When Clearing Trace Memory If you use the Monitor regularly for the same patient, you will probably want to retain her patient identification data, so you do not have to reinput it each time you send a trace. Scan *Keep Patient Data after Transmission* once. The monitor will retain the following data, even after the storage is cleared:

- patient identification
- patient phone number
- receiver phone number

This becomes the default setting and remains unless you subsequently scan *Clear Patient Data after Transmission*.

Clear Patient Data after Transmission or When Clearing Trace Memory If you use the Monitor for many different patients, you will want to clear patient identification data after each transmission. Scan *Clear Patient Data after Transmission* once. When the storage is cleared, the monitor erases:

- patient identification
- patient phone number

It retains the receiver phone number. This becomes a default setting and remains unless you subsequently scan *Keep Patient Data after Transmission*.

Clearing Memory

To prevent accidental erasure of data, the instruction *Clear Memory* requires two scans of the Barcode Reader. To clear all fetal trace data stored in the memory:

1. Scan the barcode *Clear Memory*.
2. The first scan displays the amount of fetal trace stored (in minutes) in memory.
3. On the second scan, any fetal trace stored in the systems memory is cleared and **0** is briefly displayed, showing the memory is empty.

The *Clear Memory* barcode is used to clear any fetal trace stored in memory (use the *Stop Storing* barcode if you wish to halt either the storage or transmission of data). If the barcode *Clear Memory* is scanned during either the process of storage or transmission, the command is ignored.

Patient ID and Phone Number are cleared only if your monitor defaults to *Clear Patient Data after Transmission*.

Starting Storage To record fetal trace data and store it in memory:

1. When the barcode *Start Storing* is scanned, **0** is briefly displayed, indicating that the trace memory is empty.
2. The **0** displayed then clears. The normal transducer display is given and two flashing decimal dots (three in the case of the Series 50 A Dual Ultrasound model) flash on and off (2Hz) indicating that storage is taking place.

3. The decimal dots continue to flash until storage is stopped. Then the dots are displayed continuously to indicate that a trace is stored in memory.

If the barcode *Start Storing* is scanned and the memory is not empty, the fetal trace stored in the memory is briefly displayed (in minutes). But since the memory already has data stored, the *Start Storing* command is ignored.

If you want to store a new trace, scan the *Clear Memory* barcode twice (used to clear a fetal trace stored in memory) and scan the *Start Storing* barcode.

If the barcode *Start Storing* is scanned and the storage process is already running, the amount of fetal trace stored (in minutes) is displayed briefly. But since storage is already in operation the *Start Storing* command is ignored.

Displaying Memory

To determine the amount of fetal trace (in minutes) stored in the memory:

1. Scan the barcode *Display Memory*. The fetal trace stored in memory is then briefly displayed (in minutes) and then clears.

Whenever the decimal dots are displayed, the barcode *Display Memory* can be scanned to determine the amount of trace stored in memory. This will not affect either the storage or the transmission processes.

Stopping the Storage or Transmission of Data

To halt either fetal trace storage, or the transmission of data:

1. Scan the barcode *Stop Storing*.
2. If either fetal trace storage, or the transmission of data is in process when the *Stop Storing* barcode is scanned, the process is halted.
3. The amount of fetal trace stored in memory (in minutes) is briefly displayed.

Transmitting Data

To transmit stored fetal trace data to the receiver station:

1. Connect the phone line.
2. Scan the barcode *Transmit Data* (if *Transmit Data* is scanned while the fetal trace is being stored, the storage of data is halted). The amount of fetal trace stored in the memory is displayed (in minutes) while transmission takes place.
3. Once the modem has made the telephone link with the remote receiver station, the stored fetal trace is transmitted. The amount of fetal trace displayed (in minutes) then counts down until at 0, all the data has been transmitted.
4. If the transmission of the stored trace is successful, a double tone sounds (beep, beep!) in acknowledgment and the display clears.
5. The trace is automatically erased from the fetal monitor after a successful transmission.

If transmission problems occur, the fetal monitor automatically attempts to resend the remaining trace (up to three times). If these retries fail, and data transmission stops, you will see the error message **ERR77** and hear a triple beep tone (beep, beep, beep!). The fetal monitor will make no more attempts to resend data. Acknowledge the error message by scanning the barcode *Display Memory* or by pressing a key, such as . You can try to send the remaining trace at a later time. If this problem persists, refer to “Troubleshooting and Error Messages” on page 167.

If the barcode *Transmit Data* is scanned and the transmission of the stored trace is unsuccessful:

1. The error message **Err 77** is displayed and a triple tone (beep, beep, beep!) is produced. Acknowledge the error message by scanning the barcode *Display Memory* or by pressing a key, such as .
2. The error message **Err 77** clears and two (three in the case of the Series 50 A Dual Ultrasound model) decimal dots are permanently displayed, indicating that fetal trace data is still stored in the memory.

When fetal trace data is sent to the receiver, it is sent in data-blocks (or packages). If a package is received successfully, the next package is sent - and so on until all data has been received successfully. If transmission is interrupted, scan the barcode *Transmit Data* to start the transmission process again. The system *remembers* the last package that was received successfully and continues with the next package.

If the barcode *Transmit Data* is scanned and no fetal trace is stored in memory, **0** is briefly displayed. Since there is no data stored, no transmission takes place.

PCMCIA Card Modem

The modem interface module accepts PCMCIA card modems only. To fit the PCMCIA card modem follow the manufacturer's recommendations. An **Err 70** error message accompanied by three tones (beep, beep, beep!) if:

- The modem is defective.
- The modem is installed incorrectly.
- The modem is not compatible (not a model approved by Philips).
- The interface board is faulty.

The PCMCIA card modem is not supplied by Philips. If it is found to be faulty, contact the card's supplier.

Note— Only use PCMCIA card modems approved by Philips.

Modem Compatibility

To ensure compatibility with local telephone systems, modems must be obtained locally. The following table shows which modems are currently suitable for remote trace transmission to an obstetrical information surveillance system such as OB **TraceVue** in the countries listed. As modem technology changes rapidly, we recommend that you consult the Philips Technical Marketing information pages "SoftServer" on the Intranet at <http://www-softserver.germany.agilent.com> for up to date information on modem compatibility.

Table 11-17

	Fetal Monitor Sender Modems (PCMCIA)
Europe, Australia	MT1432 LT1 MT2834 LT1 PSION DACOM Gold Card Global 56k + FAX ELSA MicroLink 56k MC
USA, Canada	MT1432 LT MT2834 LT PSION DACOM Gold Card Global 56k + FAX ELSA MicroLink 56k MC

See the website <http://www.multitech.com> for more information on MultiTech modems and distribution. The ELSA MicroLink modem 56k is available from local ELSA dealers or distributors.

Modem Initialization

The fetal monitor modem initialization commands (for Multitech modems) are:

- AT M1 speaker on until connected
- E0 no local echo
- Q0 enable results codes
- V0 not verbose result codes
- \$BA0 disable baud rate adjust
- &E4 use hardware handshake
- S2=43 escape character is +
- S7=50 dial time is 50 seconds

Using the Modem Setup Barcodes

You do not need these barcodes when working with standard telephone lines. You may need them to configure the modem for special conditions such as local branch exchange. Ensure that the operating instructions for the PCMCIA-modem are available. You can cancel the setup at anytime by scanning the "Cancel Modem Setup" barcode. See -170 for the service barcodes.

- Programming a Modem Setup Sequence**
1. Scan the “Start Modem Setup” barcode.
 2. Use the barcodes to enter the setup according to the operating manual of the modem you are using.
 3. Scan “Finish Modem Setup” to enter the modem setup you have just programmed.
 4. Check the operation of the setup by using the codes on the Patient Identification barcode sheet.

- Permanently Storing a Modem Setup Sequence**
- Scan the following barcodes, in the order given below:
1. Start Modem Setup
 2. Store Settings
 3. Finish Modem Setup

To erase your custom setup, and restore the factory setting, scan *Recall Factory Setting of Modem*.

List of Parts

Description	Part Number
Interface Board	M1353-69532
Barcode Overlay	M1353-44312
Cable Fasteners (x4 at 20cm)	1400-0507
Velcro-Type Strip (20cm)	0570-0634

Troubleshooting and Error Messages

All the standard fetal monitor error messages listed in “Operator Error Messages” on page 69 remain the same once the modem interface module option has been added. The additional error messages unique to this option are:

1. **Err 70** PCMCIA card modem not responding, accompanied by three tones (displayed for 10 seconds).
 - *The Modem is either incorrectly installed, faulty or not an approved model.*

2. **Err 77** Telephone transmission failed, accompanied by three tones (displayed for ten seconds).
 - *The telephone line is either busy, faulty, disconnected, or the Tone/Pulse information is missing. If the line is busy wait a short time and transmit the data again, if the Tone/Pulse information is missing correct it and transmit the data again.*
3. **Err 532** Interface board failed (displayed for ten seconds).
 - *Failure of the 532 Board will prevent data from being transmitted and may possibly generate **Err 70** and/or **Err 77** messages.*

In the event of a **power fail**, the normal Series 50 A/IP features apply, in addition to these:

- Fetal trace storage can not be continued after a mains failure. If the length of the stored trace following a mains failure is not large enough, clear the memory and record a new fetal trace.
- If the transmission of fetal traces is interrupted by a mains failure, the stored minutes can still be transmitted.
- If the power supply fails and the internal batteries are flat, any fetal trace stored in the memory is lost. The loss of memory will be accompanied by the loss of date/time, Toco offset and the error log. Once the power supply is reinstated the real time clock will restart and display:
4.4.44 00:00.

If the transmission sequence goes smoothly through the start phase, dialing phase and even begins the transmitting phase, but then stops each time you try to send, the problem could be that the serial number of the sending fetal monitor is not configured correctly at the receiving OB **TraceVue** system. Check this at the receiver site.

Telephone Connection

Telephone wall jack connections will differ from one country to another. To determine the appropriate telephone jack needed to connect the PCMCIA card modem to the telephone network of a particular country, contact the card's suppliers.

Telephone switching systems can differ from region to region (larger buildings/ organizations may also have their own exchange). Older telephone exchanges use a **Pulse** switching system, while more modern ones use a **Tone**. Having determined which system is used, first enter the appropriate *Pulse* or *Tone* barcode before scanning the digits of the Patient or the Receiver phone number.

Failure to scan the appropriate *Pulse* or *Tone* barcode before entering the Patient or the Receiver phone number, will result in the error message **Err 77** (phone transmission failed), accompanied by three tones beep!) when the fetal trace data is transmitted.

If you are unable to transmit a stored fetal trace, having selected the appropriate *Pulse* or the *Tone* barcode, follow the steps listed below until the problem is resolved:

1. Switch on the recorder and enter the receiver-phone number.
2. Look on the recorder print-out and check the receiver phone number is correct. If it is not, follow the instructions given in the section *Setting the Receiver Phone Number* found in this chapter.
3. Using a telephone on the same line, call the receiver number and check if it is clear, engaged or disconnected. If there is a problem with the telephone line contact the telephone service supplier.
4. Check that the PCMCIA card modem is approved by Philips and that it and the connections between the modem and the telephone wall jack are correctly fitted in accordance with the telephone line supplier and the modem manufacturers recommendations.
5. Check the printed recorder trace to see if the correct *Pulse* or *Tone* barcode has been scanned when the *Receiver Phone Number* was entered (a **P** or a **T** is printed on the trace to indicate this). If the incorrect *Pulse* or *Tone* barcode has been scanned follow the instructions given in the section *Setting the Receiver Phone Number* in this chapter. To confirm whether the exchange you are using is **Pulse** or **Tone**, contact your telephone service supplier. Alternatively telephone the Receiver Phone Number and listen to the line being connected. If the telephone line clicks during dialing (caused by the operation of relays at the exchange) then the system is **Pulse**, if it makes a series of electronic sounds, then the exchange is **Tone**.

Transmission problems associated with the interface board raise the error message **Err 532**. To determine the source of any problem follow the instructions listed in Chapter 8, "Troubleshooting Flowcharts."

If transmission problems are due to a faulty modem card the error message **Err 70** is raised. If the problem is either PCMCIA card modem or telephone line based, repair or replacement is the responsibility of the supplier.

Private phone switching systems sometimes do not use Tone or Pulse dialling. Proper operation of the remote transmission is not possible with some of these systems.

Modem Setup Barcodes

The following are the service barcodes for modem setup. See page 166 for instructions on how to use them.

Service Barcodes

Table 11-18Service Barcodes

Start Modem Setup



A



B



C



D



E



F



G



H



I



J



K



L



M



N



O



P



Q



R



Table 11-18 Service Barcodes





	S		T
			
U		V	
			
	W		X
			
Y		Z	
			
	1		2
			
3		4	
			
	5		6
			
7		8	
			
	9		0
			
%		\$	
			
	-		
			

Table 11-18 Service Barcodes

Recall Factory Setting of Modem



Blind Dial



Store Setting



Cancel Modem Setup



Finish Modem Setup



B

Safety and Environment

Safety Information

Follow these guidelines for maximum patient safety:

Protective Earth Check each time before use that the Monitor is in perfect working order and properly grounded.

Warning

Shock hazard: any interruption of the protective earth grounding will cause a potential shock hazard that could result in serious personal injury. Whenever it is likely that the protection has been impaired, the Monitor must be made inoperative and be secured against any unintended operation.

-
- To protect hospital personnel and the patient, the cabinet must be grounded. Accordingly, the Monitor is equipped with a 3-wire power cable that grounds it to the power line ground when plugged into an appropriate 3-wire receptacle. Do not use a 3-wire to 2-wire adapter with the Monitor.
 - Position the patient cable so that it does not come into contact with any other electrical equipment. The cable connecting the patient to the Monitor must be free of electrolyte.
 - Make sure that the Monitor is free from condensation during operation. This can form when equipment is moved from one building to another, and is exposed to moisture and differences in temperature.

Warning

There is a possible explosion hazard if the Monitor is used in the presence of flammable anesthetics. Always disconnect the Monitor from the power supply before removing the top cover. If servicing requires that the power be on while the cover is removed, proceed with extreme caution. Failure to do so can result in serious injury.

Patient Safety



The Monitor should only be used by, or under the direct supervision of, a licensed physician or other health care practitioner who is trained in the use of fetal heart rate monitors and in the interpretation of fetal heart rate traces.

Environment





The Monitor is designed to fulfill safety requirements according to IEC 60601-1, UL 544 and CSA C22.2-601.1-M90. It is not intended to be used for direct cardiac application and it is not defibrillator-protected.

In the following tables, the symbol  depicts a floating condition for resulting isolation after connecting a transducer or patient module.

Series 50 A

Parameter	Monitor Input Connector (Class)	Resulting Isolation with transducer/patient module
External Toco transducer (M1355A) Ultrasound transducer (M1356A)	B	BF 
Remote event marker (15249A)	B	BF 

Series 50 IP-2

Parameter	Monitor Input Connector (Class)	Resulting Isolation with transducer/patient module
External Toco transducer (M1355A)	CF	CF 
IUP quartz transducer (1290C) IUP pressure transducer (CPJ840J5)	CF	CF 
Ultrasound transducer (M1356A)	B	BF 
DECG transducer (M1357A) MECG transducer (M1359A) ECG only patient module (M1364A)	B	CF 
Remote event marker (15249A)	B	BF 

Environment

Use the monitor in an environment that is reasonably free from vibration, dust, corrosive or explosive gases, flammable agents, extremes of temperature, humidity and so forth. It operates within specifications at ambient temperatures between 0 and 55°C. Ambient temperatures that exceed these limits can affect the accuracy of the monitor and cause

damage to the components and circuits. Only products that fulfil the necessary safety and electrical standards should be used in conjunction with the monitor (contact your local response center for details).

Allow at least 5cm (2in) clearance around the monitor for proper air circulation. If the monitor is mounted in a cabinet, allow sufficient space at the front for operation and at the rear for servicing with the cabinet door open.

Spillage

If liquid enters the monitor, you must cease using it immediately. Contact an authorized engineer for a safety inspection.

Electromagnetic Compatibility (EMC) Specifications

The Electromagnetic Compatibility (EMC) specifications in this chapter supplement those given in the *Instructions for Use*.

Emissions and Immunity

The product is designed and evaluated to comply with the emissions and immunity requirements of international and national EMC standards.

The EMC standards state that manufacturers of patient-coupled equipment must specify immunity levels for their systems. See Tables 2, 3 and 4 for this detailed immunity information. See Table 5 for recommended minimum separation distances between portable and mobile communications equipment and the product.

Immunity is defined in the standard as the ability of a system to perform without degradation in the presence of an electromagnetic disturbance.

Caution should be exercised in comparing immunity levels between different devices. The criteria used for degradation are not always specified by the standard and can therefore vary with the manufacturer.

Electromagnetic Emissions

Table 1

Emissions test	Compliance
Radio Frequency (RF) emissions in accordance with CISPR 11	Group 1
RF emissions in accordance with CISPR 11	Class B
Harmonic emissions IEC 61000-3-2	Class A
Voltage fluctuations and flicker IEC 61000-3-3	Complies

Electromagnetic Immunity

The M1351A/M1353A (referred to in the following sections as the 'device') is suitable for use in the specified electromagnetic environment. The user or operator must ensure that it is used in the appropriate environment as described below.

Table 2

Immunity Test	IEC 60601-1-2 Test Level	Compliance Level	Electromagnetic Environment Guidance
Electrostatic discharge (ESD) IEC 61000-4-2	± 6 kV contact ± 8kV air	M1351A: ± 6 kV contact ± 8kV air M1353A: ± 4 kV contact ± 8kV air	Floors should be wood, concrete, or ceramic tile. If floors are covered with synthetic material, the relative humidity should be at least 30%.
Electrical fast transient/burst IEC 61000-4-4	± 2 kV for power supply lines ± 1 kV for input/output lines (if applicable)	M1351A: ± 2 kV for power supply lines input/output lines: not applicable M1353A: ± 1 kV for power supply lines input/output lines: not applicable	Mains power quality should be that of a typical commercial and/or hospital environment
Surge IEC 61000-4-5	± 1 kV differential mode ± 2 kV common mode	± 1 kV differential mode ± 2 kV common mode	Mains power quality should be that of a typical commercial and/or hospital environment

Table 2

Immunity Test	IEC 60601-1-2 Test Level	Compliance Level	Electromagnetic Environment Guidance
Voltage dips, short interruptions and voltage variations on power supply input lines IEC 61000-4-11	<5% U_T (> 95% dip in U_T) for 0.5 cycles 40% U_T (60% dip in U_T) for 5 cycles 70% U_T (30% dip in U_T) for 25 cycles < 5% U_T (> 95% dip in U_T) for 5 sec	0% U_T (100% dip in U_T) for 0.5 cycles 40% U_T (60% dip in U_T) for 5 cycles 70% U_T (30% dip in U_T) for 25 cycles 0% U_T (100% dip in U_T) for 5 sec	Mains power quality should be that of a typical commercial and/or hospital environment. If the user of the device requires continued operation during power mains interruptions, it is recommended that the device is powered from an uninterruptible power supply.
Power frequency (50/60 Hz) magnetic field IEC 61000-4-8	3 A/m	3 A/m	Power frequency magnetic fields should be at the levels characteristic of a typical location in a typical commercial and/or hospital environment

In this table, U_T is the a.c. mains voltage prior to application of the test level.

Finding Recommended Separation Distances

In the following table, P is the maximum output power rating of the transmitter in watts (W) according to the transmitter manufacturer, and d is the recommended separation distance in meters (m).

Portable and mobile RF communications equipment should be used no closer to any part of the device, including cables, than the recommended separation distance calculated from the equation appropriate for the frequency of the transmitter.

Field strengths from fixed RF transmitters, as determined by an electromagnetic site survey, should be less than the compliance level in each frequency range.

Interference may occur in the vicinity of equipment marked with this symbol:



Table 3

Conducted RF Immunity Test EN/IEC 61000-4-6				
IEC 60601-1-2 Test Level over 150 kHz to 80 MHz	Frequency Range (where Immunity Level is below IEC 60601-1-2 Test Level at certain frequencies)	Known RF Sources within Frequency Range	Worst Case Immunity Level within Frequency Range	Electromagnetic Environment Guidance: Recommended Separation Distance (<i>d</i>) (in Meters, at Frequency Range Tested) for Ultrasound and ECG Measurements
<p>Note: The device meets the compliance level of 3.0 V_{RMS} according to IEC 60601-1-2 for most of the specified test frequency range. However, within the frequency ranges specified in this table, there are some frequencies at which the immunity level is below the IEC 60601-1-2 test level. Within each frequency range, the worst case immunity level is given. Over the frequency range 150 kHz to 80 MHz, the recommended separation distance in meters (<i>d</i>) is found by the following equation:</p> $d = \left(\frac{3,5}{V1}\right) \sqrt{P}$ <p style="text-align: center;">For a compliance level of 3.0 V_{RMS}:</p> $d = 1,2 \sqrt{P}$				
M1351A				
3.0 V	0.5 MHz - 1.6 MHz	Medium Wave (AM) radio stations	0.2 V @ 1.034 MHz	$d = 17,5 \sqrt{P}$
M1353A				
3.0 V	0.5 MHz - 1.6 MHz	Medium Wave (AM) radio stations	0.2 V @ 1.034 MHz	$d = 17,5 \sqrt{P}$
	1.6 MHz - 3.0 MHz	Commercial radio stations, marine radio service, marine navigation, amateur radio, aircraft radio	0.6 V @ 2.998 MHz	$d = 5,8 \sqrt{P}$
<p>Key: <i>d</i> = Recommended separation distance in meters (m) <i>P</i> = maximum output power rating of the transmitter in watts (W) according to the transmitter manufacturer <i>V1</i> = Tested compliance level (in Volts) for the Conducted RF Immunity test IEC 61000-4-6</p>				

Table 4

Radiated RF Immunity Test EN/IEC 61000-4-3			
IEC 60601-1-2 Test Level and Specified Test Frequency Range	Compliance Level	Immunity Level	Electromagnetic Environment Guidance: Recommended Separation Distance (d) (in Meters, at Frequency Range Tested) for Ultrasound and ECG Measurements
Note: The device meets the compliance level of 3.0 V/m according to IEC 60601-1-2 for the specified test frequency range. Over the frequency range 80 MHz to 800 MHz, the recommended separation distance in meters (d) is found by the following equation: $d = \left(\frac{3,5}{E1}\right)\sqrt{P}$ For a compliance level of 3.0 V/m: $d = 1,2\sqrt{P}$			
Note: Over the frequency range 800 MHz to 2.5 GHz, the recommended separation distance in meters (d) is found by the following equation: $d = \left(\frac{7,0}{E1}\right)\sqrt{P}$ For a compliance level of 3.0 V/m: $d = 2,3\sqrt{P}$			
3 V/m 80 MHz to 800 MHz	3.0 V/m	3.0 V/m	$d = 1,2\sqrt{P}$
3 V/m 800 MHz to 2.5 GHz	3.0 V/m	3.0 V/m	$d = 2,3\sqrt{P}$
Key: d = Recommended separation distance in meters (m) P = maximum output power rating of the transmitter in watts (W) according to the transmitter manufacturer E1 = Tested compliance level (in Volts/meter) for the Radiated RF Immunity test IEC 61000-4-3			

Field strengths from fixed transmitters, such as base stations or radio (cellular, cordless) telephones and land mobile radios, amateur radio, AM and FM radio broadcast and TV broadcast cannot be predicted theoretically with accuracy. To assess the electromagnetic environment due to fixed RF transmitters, an electromagnetic site survey should be considered. If the measured field strength in the location in which the device is used exceeds the applicable RF compliance level above, it should be observed to verify normal operation. If abnormal performance is observed, additional measures may be necessary, such as reorienting or relocating the device.

These guidelines may not apply in all situations. Electromagnetic propagation is affected by absorption and reflection from structures, objects, and people.

If you require further information or assistance, please contact Philips Support.

Recommended Separation Distances from Portable and Mobile RF Communication Equipment

The device is intended for use in an electromagnetic environment in which radiated RF disturbances are controlled. The customer or user of the device can help prevent electromagnetic interference by maintaining a minimum distance between portable and mobile RF communications equipment and the device as recommended below, according to the maximum output power of the communications equipment.

Table 5

Rated Maximum Output Power (P) of Transmitter (in Watts)	Separation Distance (d) in Meters According to Frequency of Transmitter at IEC 60601-1-2 Test Compliance Level (Figures in brackets show worst-case separation distances where tested values fall below the compliance level at certain frequencies. See previous table.)		
	150 kHz to 80 MHz	80 MHz to 800 MHz	800 MHz to 2.5 GHz
	$d = \left(\frac{3,5}{V1}\right)\sqrt{P}$	$d = \left(\frac{3,5}{E1}\right)\sqrt{P}$	$d = \left(\frac{7,0}{E1}\right)\sqrt{P}$
0.01	0.1 (1.8)	0.1	0.23
0.1	0.4 (5.5)	0.4	0.7
1	1.2 (17.5)	1.2	2.3
10	3.8 (55.3)	3.8	7.3
100	12.0 (175.0)	12.0	23.0

Introduction

This section tells you how to use an upgrade key to upgrade the software of the Philips Series 50 A and IP-2 fetal monitors. Option C01 (adding twin ultrasound capability), applies only to the 50 A .

Upgrade Procedure

1. Disconnect all transducers (and telemetry) from the monitor.
2. Switch on the monitor.
3. Plug the upgrade key into the service socket (see Figure 1-1 on page 5) on your monitor (if applicable, first remove the little plastic cap on the service socket).
 - The “start upgrade” tone sounds (two short beeps) when the upgrade begins.
 - After about 45 seconds the fetal monitor display should change to “-8-”.
 - Within 7 minutes, the display counts down to “-0-”.
4. At the end of the procedure, you will hear the “upgrade successful” tone (a continuous beep lasting two seconds). The monitor display shows “-0-”. Unplug the upgrade key from the monitor.

If you don't hear the “start upgrade” tone or you hear the “upgrade failed” tone (a series of short beeps lasting 2 seconds), there may be several reasons:

 - The battery in the upgrade key may be low. Replace the battery.
 - You may already have carried out the maximum number of upgrades. The upgrade key is programmed to perform the number of upgrades ordered, to a maximum of 8.

If you hear the upgrade failed tone, (a series of short beeps lasting 2 seconds), disconnect the upgrade key and try again from step 3 above.

If the upgrade still fails, carry out the quick test described on page 66. If the response is not the same as that described in this manual, contact Philips Support Service.

5. Write the serial number of the upgraded monitor in the space provided on the key. In this way you can keep a record of the monitors that have been upgraded.

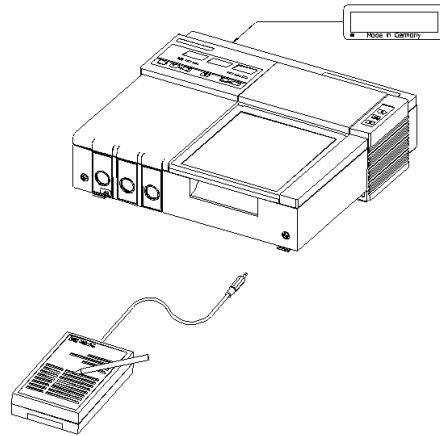

6. Stick the feature label to the front of the monitor, as in the example below:
A: Fetal Movement Profile
B: Dual Ultrasound

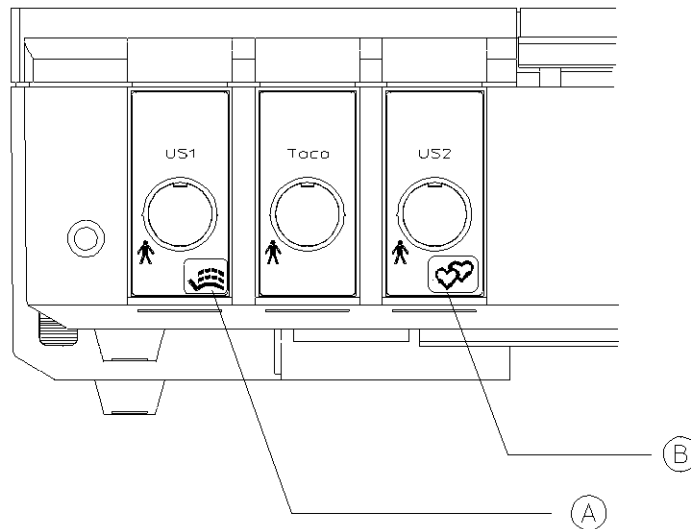

7. Switch the monitor off and then on: it will perform the power-on self-test. If an error message is displayed, contact Philips. If “-8-” is displayed, the upgrade was not successful. Try the upgrade again from the beginning.
If “--- --- ---” is displayed, the new software is installed and checked. Please refer to the *Instructions for Use* for information on necessary performance assurance.

Repeat steps 1 to 7 for each monitor to be upgraded.

When the upgrade key has performed as many upgrades as it was programmed to perform, return it to Philips for recycling. Please contact your nearest Philips Service Center for details.

A

Accessories
 optional, 11
accessories, 9
 parts list, 126

B

barcode booklets, part numbers, 10
barcode reader, 109
 connecting, 108
 fitting holder, 24
 modem interface module, 159, 160
 testing, 110
batteries, replacing, 138
baudrate settings, 111
boards
 part numbers, 120

C

cables
 remote event marker, 17
 transducer, 17
care and cleaning, 95, 96
 monitor, 95
carts
 replacement parts, 24
 specifications, 24
chassis, replacing, 144
clearing the error log, 38
combined
 interface board, functional
 description, 60
combined interface module
 fitting, 107
 specifications, 16
configuring the monitor
 using a PC, 29
 using barcodes, 29
 using pushbuttons, 26
 using the service program, 32
connecting
 barcode reader, 108
 NIBP monitor, 108
 OB TraceVue, 108
 PC to monitor, 31
 peripheral devices, 108
 telemetry system, 108
CPU board
 functional description, 56
 removing, 142
cyclic test
 using the service program, 35

D

date and time
 formatting, 26
 setting, 47
DECG parameter test, 88
DECG transducer
 parts list, 130
 specifications, 18
digital connection
 OBMS, 10
digital interface protocol specifications,
 part numbers, 10
display
 board removing, 147
 board, functional description, 58

 specifications, 14
 displaying memory
 modem interface module, 164
documentation, 10
drawer assembly
 replacing, 151

E

earth
 protective, 173
electromagnetic emissions, 176
emissions
 electromagnetic, 176
Enclosure leakage current SFC open
 earth test, 104
environment, 13, 174
equipment type, 174
error flowchart
 error 500, 72
 error 501, 74
 error 502, 76
 error 503 and 513, 78
 error 510, 79
 error 511, 74
 error 512, 74
 error 531, 80
 error 532, 81
 error 601, 84
 error 610, 85
 error 611, 86
 error 70, 82
 error 77, 83
error log
 clearing, 38
 clearing using the service program, 40
 printing, 38
 reading in the service program, 37
 writing in the service program, 37
error messages, 69
external devices
 barcode reader, 108, 109
 NIBP monitor, 108, 111
 serial interface, 109
 telemetry interface, 108
external maternal parameters
 NIBP monitors, 111

F

fetal pulse oximetry
 enabling, 26
FHR trace
 maternal measurements, 112
flowchart
 FSpO2, 93
flowcharts
 DECG parameter test, 88
 error 500, 72
 error 501, 74
 error 502, 76
 error 503 and 513, 78
 error 510, 79
 error 511, 74
 error 512, 74
 error 531, 80
 error 532, 81
 error 601, 84
 error 610, 85
 error 611, 86

 error 70, 82
 error 77, 83
 Maternal NIBP, 91, 92
 MECG parameter test, 89
 paper sensing test, 94
 Toco parameter test, 90
 ultrasound parameter test, 87
frontend board
 functional description, 52, 54
 removing, 140
FSpO2
 connecting, 113
 connecting to the monitor, 108
 enabling, 26
functional description
 Combined Interface board, 60
 CPU board (M1353-66503), 56
 display board (M1350-66520), 58
 frontend board (M1353-66501), 52
 frontend board (M1353-66511), 52
 frontend board (M1353-66512), 52
 frontend board (M1353-69516), 54
 modem interface board, 60
 power supply board (M1353-
 66502), 55
 recorder board (M1353-66510), 59
 system overview, 49
fuse
 part numbers, 141
 removing, 137
 values, 137

G

gain
 external Toco, 27

I

information
 general, 4
input specifications, 14
installing the service program, 30
Instrument safety test, 105
interface
 module removing, 143
 module, fitting maternal
 parameters, 107
IUP
 formatting, 28
 setting scale, 26
IUP transducer
 specifications, 19, 20
 testing, 99

L

language option
 setting, 26
loading the service program, 31
loudspeaker
 loudspeaker error 610, 85
 loudspeaker error 611, 86
 loudspeaker, removing, 149

M

M1351A
 functional description, 7
M1353A
 functional description, 8

- maternal measurements on the FHR
 - trace, 112
- maternal parameters, 107
 - baudrate settings, 111
 - NIBP monitors, 111
- MECG parameter test, 89
- MECG transducer
 - parts list, 131
 - specifications, 18
- mechanical inspection, 96
- Metron
 - contact address, 101
- modem
 - no response 70, 82
 - PCMCIA, 165
 - transmission 77, 83
- Modem initialization, 166
- modem interface board, functional
 - description, 60
- Modem Interface Module, 143
- modem interface module, 157, 162
 - barcode reader, 159, 160
 - displaying memory, 164
 - fitting, 157
 - patient ID, 162
 - peripheral devices, 158
 - specifications, 16
 - starting storage, 163
 - stopping storage, 164
 - telephone connection, 168
 - transmitting data, 164
 - troubleshooting, 167
- Modem setup, 166
 - cancelling, 166
 - erasing, 167
 - programming, 167
 - restoring factory default, 167
 - storing, 167
- monitor
 - accessories, 9
 - angle mounting, 21
 - care and cleaning, 95
 - configuring, 25
 - configuring options, 27
 - configuring using a PC, 29
 - configuring using barcodes, 29
 - configuring using pushbuttons, 26
 - dimensions, 13
 - fitting the paper take-up tray, 23
 - installation, 21
 - safety test, 65
 - specifications, 13
 - surface mounting, 21
 - testing, 65
 - wall mount dimensions, 22
 - wall mounting, 22
- mounting
 - on carts, 24
- N**
- N-400
 - connecting to the monitor, 108
- NIBP monitor
 - baudrates, 111
 - connecting, 108
 - connections, 111
 - maternal measurements, 112
 - NST timer options, 27

- O**
- OBMS
 - connecting to the monitor, 108
 - digital connection, 10
 - pin connections, 117
- ODIS
 - connecting to the monitor, 108
 - pin connections, 117
- on/off switch, removing, 145
- operating temperatures, 174
- Optional accessories, 11
- options
 - configuration, 27
 - NST timer, 27
- overview
 - of service tests, 65
 - product, 4
- P**
- paper
 - paper-out alert, 27
 - sensing test, 94
 - setting the format, 26
 - setting the speed, 48
 - take-up tray, fitting, 23
- parameter test, 65, 68
- part numbers, modem interface
 - module, 167
- parts
 - ordering, 119
- parts list
 - Barcode booklets, 10
 - boards, 120
 - DECG transducer, 130
 - digital interface protocol
 - specifications, 10
 - documentation, 10
 - MECG transducer, 131
 - monitor, 122, 123
 - part numbers, 10
 - service documentation, 10
 - technical data sheets, 10
 - Toco transducer, 128
 - ultrasound transducer, 129
 - video tapes, 10
- Patient leakage test, 104
- patient modules
 - specifications, 18, 136
 - testing, 99
- patient safety, 173
- PC-based configuration, 29
- PCMCIA card modem, 165
- performance assurance tests, 65
- peripherals, 107
- permanent test, 70
- phone number
 - entering patient, 162
 - receiver, 162
- pin connections
 - barcode reader, 110
 - OBMS, 117
 - ODIS, 117
 - RS232 Serial Interface, 109
 - telemetry system, 115
- power requirements, 13
- power supply
 - board replacing, 141
 - board, functional description, 55

- preventative maintenance, 96
- printhead, removing, 152
- printing the error log, 38
- program
 - adjusting the recorder, 34
- protective earth, 173
- protective earth test, 104
- Q**
- quick test, 65, 66
- R**
- reading the error log, 37
- recorder
 - adjusting, 34
 - board replacement, 146
 - interface board, functional
 - description, 59
 - paperfeed error 532, 81
 - paperfeed error 601, 84
 - removing sensing assembly, 154
 - setting the heat adjustment, 26
 - setting the paper speed, 48
 - setting the print offset, 26
 - specifications, 15
 - thermal printhead removing, 152
- recorder maintenance, 96
- reference documentation, 10
- remote event marker
 - specifications, 16
- removing the Modem Interface
 - Module, 143
- repair
 - parameter test, 68
 - quick test, 66
 - safety test, 65
- repair strategy, 1
- replacement and removal
 - batteries, 138
 - chassis, 144
 - combined interface module, 107, 143
 - CPU board, 142
 - display board, 147
 - drawer assembly, 151
 - frontend board, 140
 - fuses, 137
 - loudspeaker, 149
 - on/off switch, 145
 - power supply board, 141
 - recorder board, 146
 - recorder sensing assembly, 154
 - stepper motor, 155
 - switch board, 148
 - thermal printhead, 152
 - Toco transducer, 132
 - top cover, 139
 - transformer, 150
 - ultrasound transducer, 134
- S**
- safety
 - environment, 13
 - equipment type, 174
 - patient, 173
 - protective earth, 173
 - requirements, 173
 - symbols, 2
 - safety test, 65

- safety test connector
 - Metron, 101
- Safety test S2
 - protective earth test, 104
- Safety test S3
 - patient leakage test, 104
- Safety test S6
 - enclosure leakage current test 2, 104
- Safety tests
 - instrument safety test, 105
 - overview, 65
 - performance tests, 103
 - power on test, 103
 - visual inspection, 103
- self test, 50, 65
 - facilities, 16
 - overview, 65
- serial interface, 109
- serial number, resetting, 41
- serial number, writing, 41
- service
 - kit, 120
 - philosophy, 65
 - tests, 65
 - tests, an overview, 65
 - tools, 120
- service documentation, part numbers, 10
- service program
 - clearing the error log, 40
 - configuring the monitor, 32
 - cyclic test, 35
 - installing, 30
 - loading, 31
 - main menu, 31
 - option number, 29
 - reading options, 36
 - reading the error log, 37
 - service menu, 35
 - setting the options, 41
 - using, 31
 - writing the error log, 37
 - writing the serial number, 41
- service tests
 - overview, 65
- setting
 - IUP scale, 26
 - language option, 26
 - paper format, 26
 - paper speed, 48
 - recorder heat adjustment, 26
 - recorder print offset, 26
 - time and date, 47
 - time and date formatting, 26
- specifications
 - combined interface module, 16
 - DECG transducer, 18
 - DECG with M1362A cable, 19
 - display, 14
 - inputs, 14
 - IUP transducer, 19, 20
 - M1364A, 136
 - M1365A, 136
 - MECG transducer, 18
 - MECG with M1363A cable, 19
 - modem interface module, 16
 - recorder, 15
 - remote event marker, 16
 - self-test facilities, 16
 - Toco transducer, 17
 - spillage, 175
 - starting storage
 - modem interface module, 163
 - stepper motor, removing, 155
 - stopping storage
 - modem interface module, 164
 - switch board, removing, 148
 - symbols
 - safety, 2
 - system
 - interface, 108
 - overview, 49
- T**
- technical data sheets, part numbers, 10
- telemetry system
 - connecting to the monitor, 108
 - interface, 108
 - pin connections, 115
- testing
 - barcode reader, 110
 - booting and self test, 50
 - IUP transducer, 99
 - monitor, 65
 - parameter test, 68
 - patient modules, 99
 - permanent test, 70
 - quick test, 66
 - Toco transducer, 97
 - ultrasound transducer, 98
- theory of operation, 49
- thermal printhead, removing, 152
- time and date
 - formatting, 26, 28
 - setting, 47
- Toco
 - external Toco gain, 27
- Toco parameter test, 90
- Toco transducer
 - disassembling, 132
 - parts list, 128
 - specifications, 17
 - testing, 97
- top cover, removing, 139
- transducers
 - cables, 17
 - disassembling Toco, 132
 - disassembling ultrasound, 134
 - IUP, 20
 - specifications, 17
 - testing, 97
- transformer, removing, 150
- transmitting data, 161
 - modem interface module, 164
- troubleshooting
 - modem interface module, 167
- troubleshooting flowcharts, 71
 - DECG parameter test, 88
 - error 500, 72
 - error 501, 74
 - error 502, 76
 - error 503 and 513, 78
 - error 510, 79
 - error 511, 74
 - error 512, 74
 - error 531, 80
 - error 532, 81
 - error 601, 84
 - error 610, 85
 - error 611, 86
 - error 70, 82
 - error 77, 83
 - FSpO2, 93
 - Maternal NIBP, 91, 92
 - MECG parameter test, 89
 - paper sensing test, 94
 - Toco parameter test, 90
 - ultrasound parameter test, 87
- U**
- ultrasound parameter test, 87
- ultrasound transducer, 17
 - disassembling, 134
 - parts list, 129
 - specifications, 17
 - testing, 98
- V**
- video tapes, part numbers, 10
- voltage
 - changing fuses, 137
 - fuse part numbers, 141
 - fuse values, 137
 - OBMS output voltage values, 117
 - ODIS output voltage values, 117
 - power requirements, 13
 - protective earth, 173
 - removing the power supply, 141
- W**
- wall mount dimensions, 22
- writing the error log, 37
- writing the serial number, 41